

BAJA Project

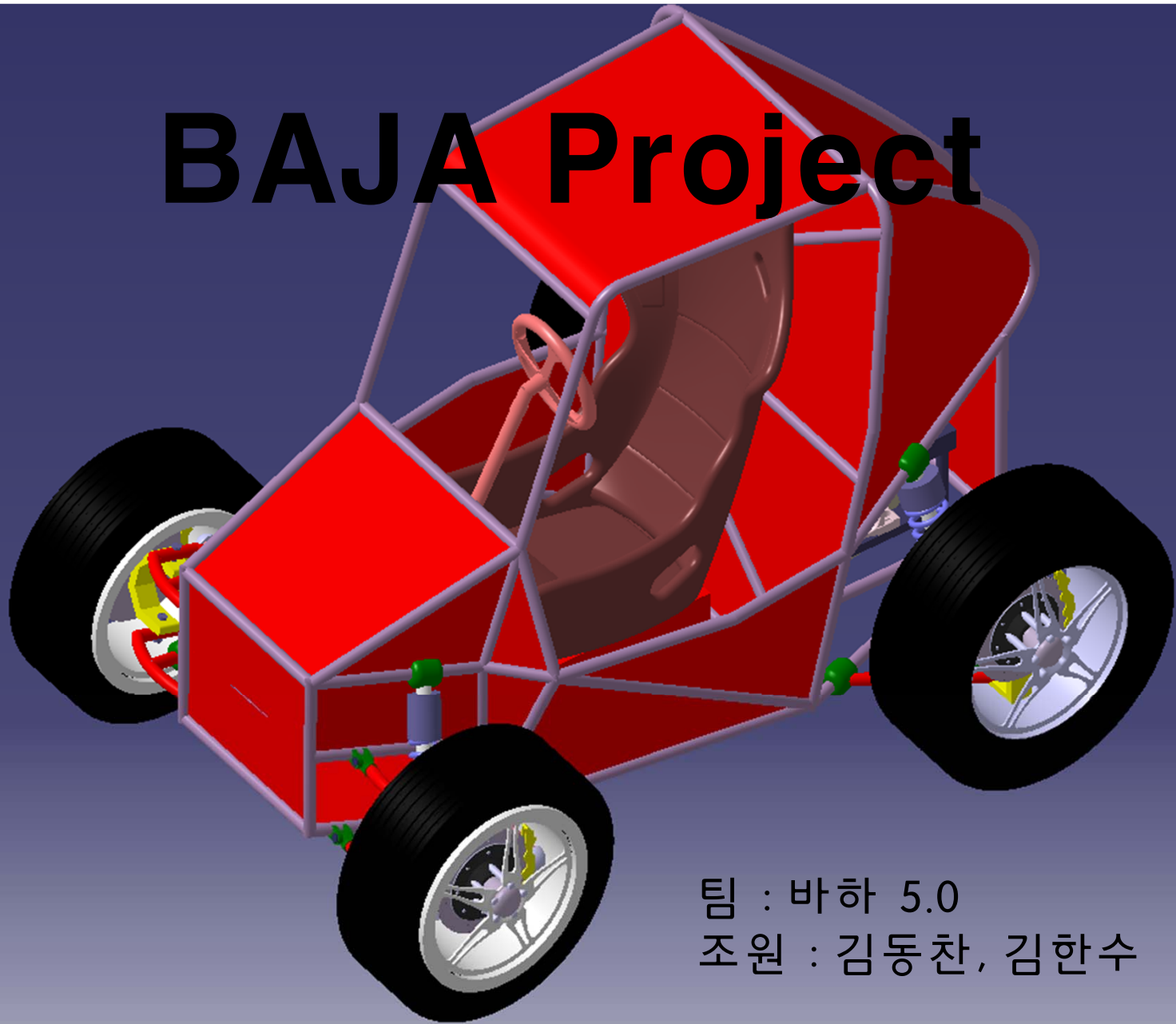

팀 : 바하 5.0
조원 : 김동찬, 김한수



Contents

1. 팀 명 선정 이유
2. 프레임 및 서스펜션
3. 휠, 브레이크 디스크, 스티어링 휠, 속업쇼바
4. 인용한 자료
5. 보완해야 할 부분

1. 팀 명 선정 이유

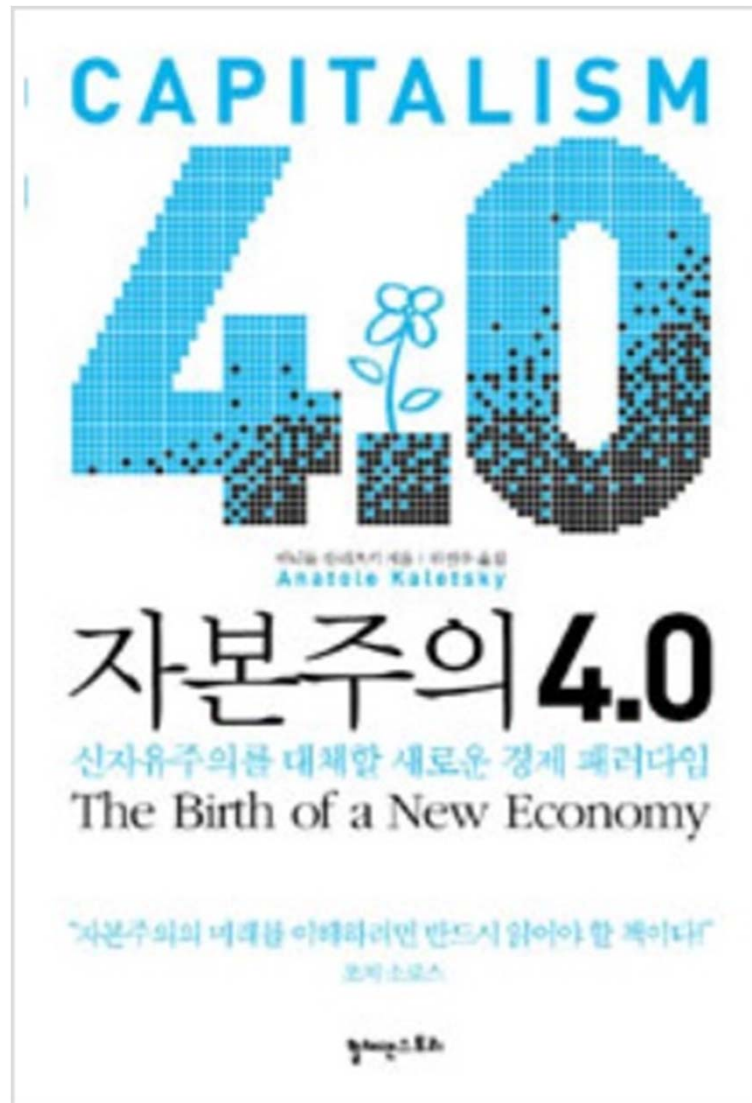

2. 프레임 및 서스펜션

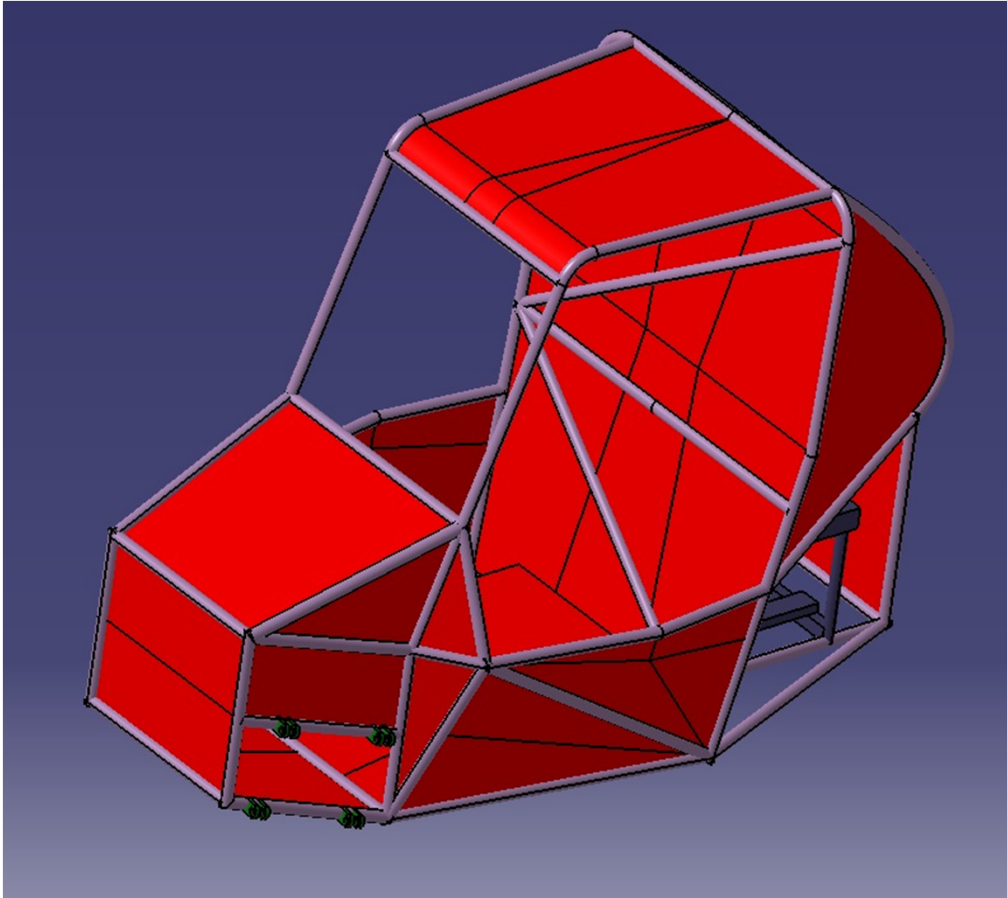

<참고자료>

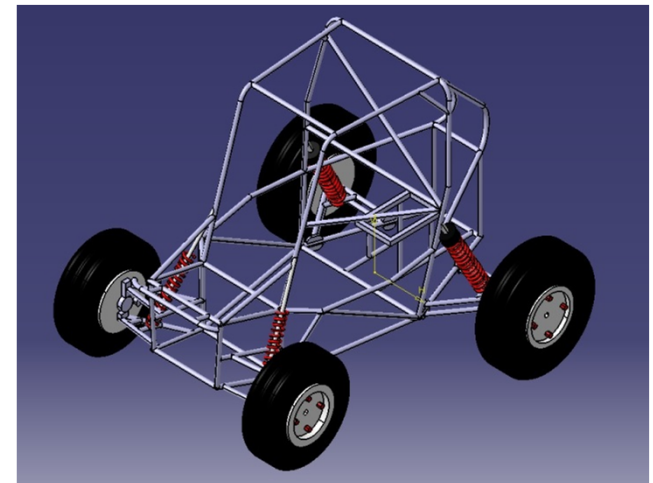

앞 쪽 서스펜션

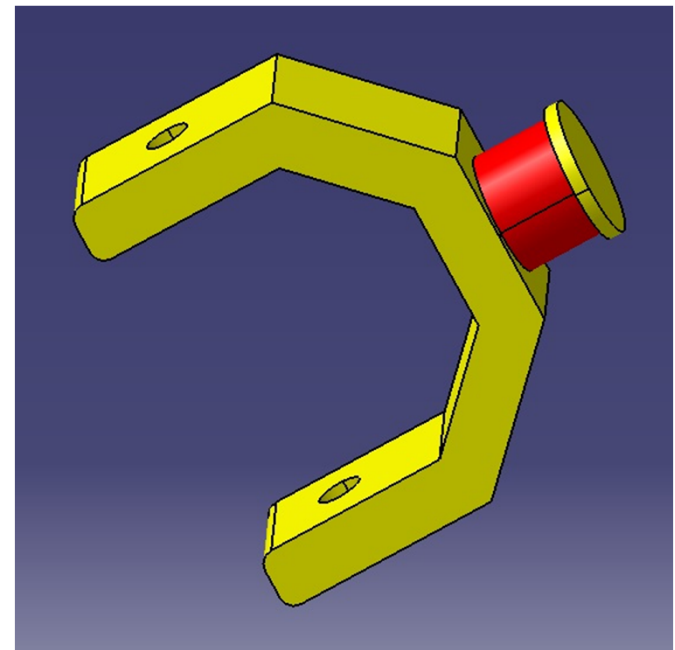
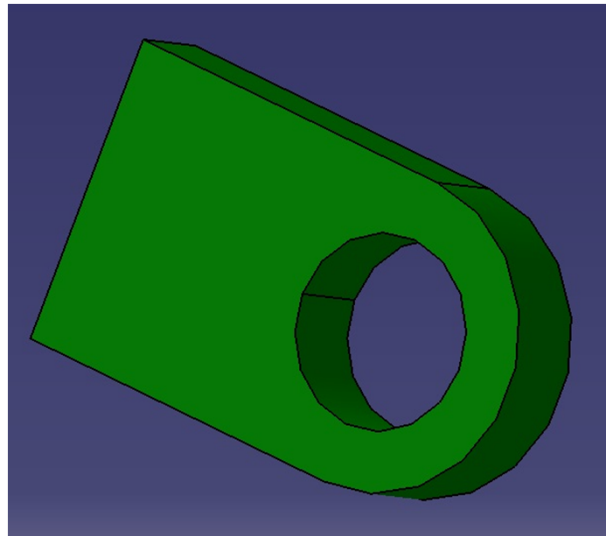
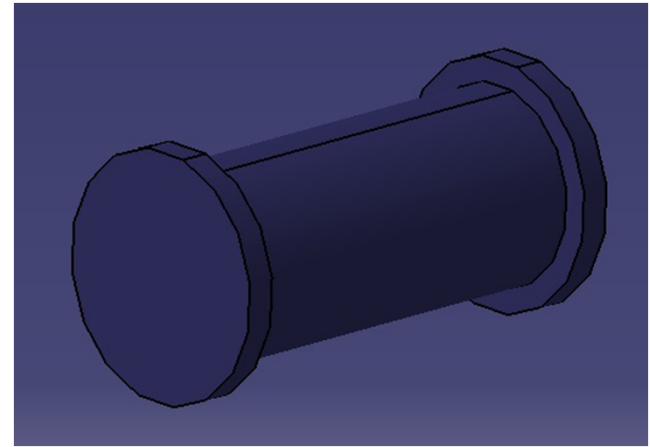
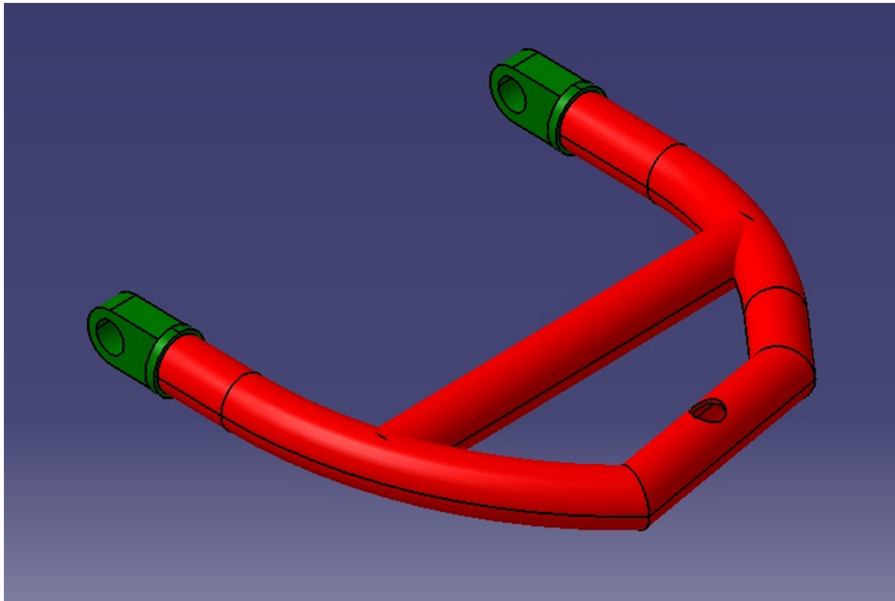

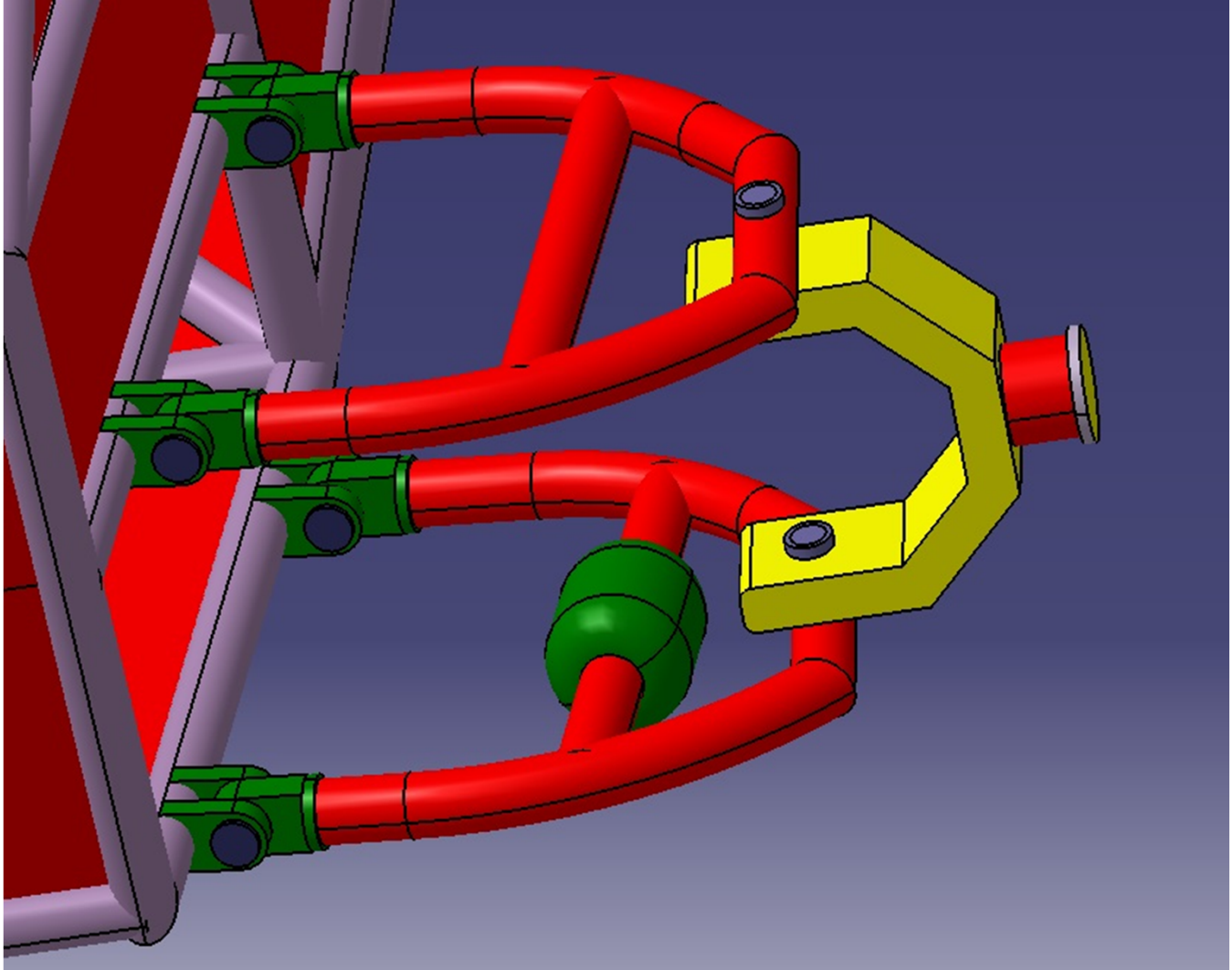
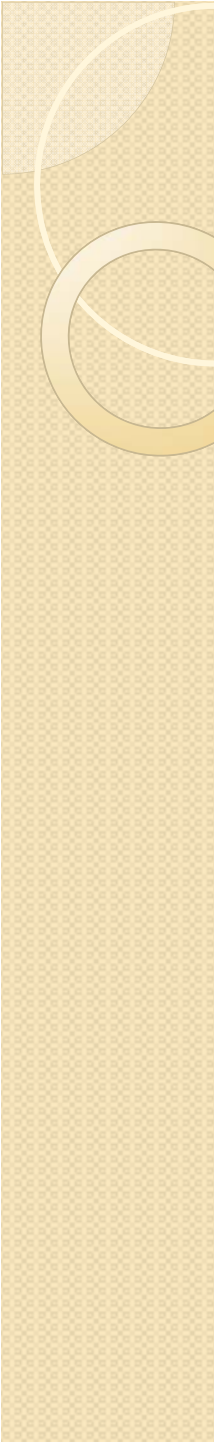

뒤 쪽 속업쇼바

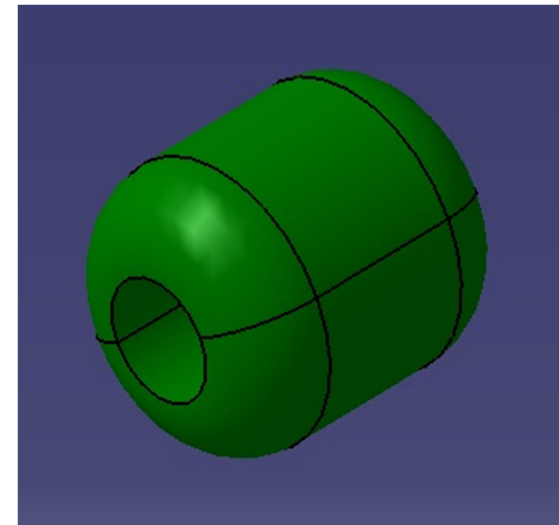
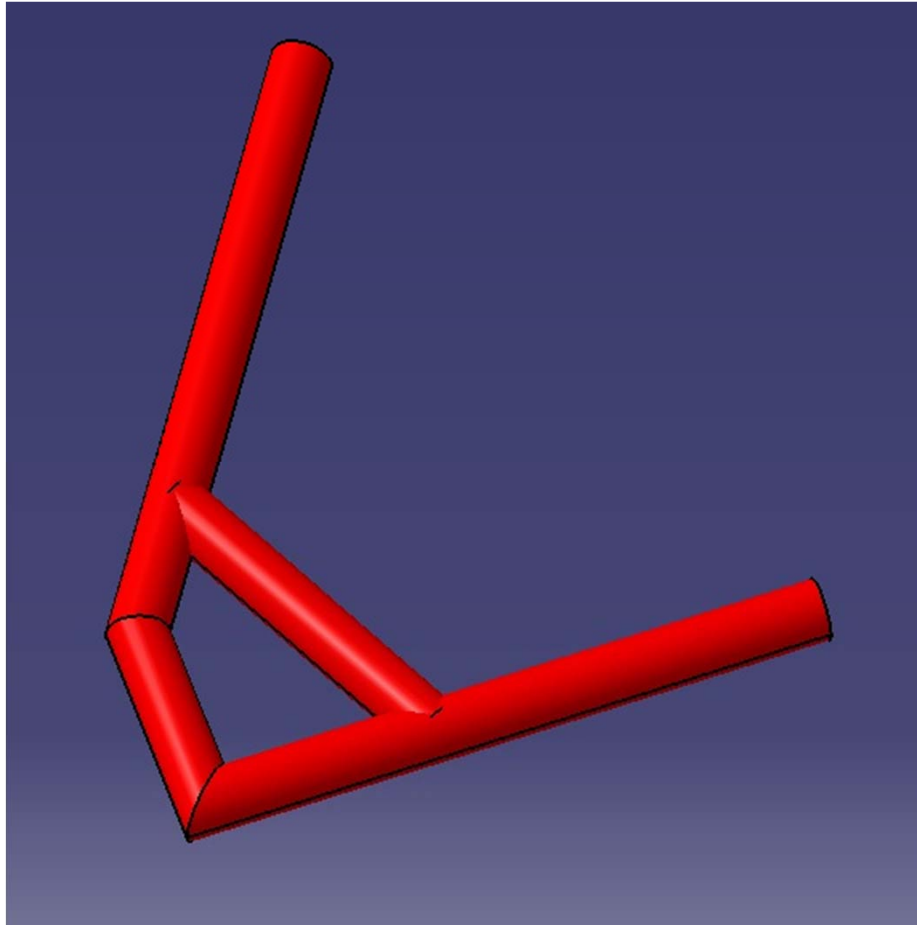

3. 휠, 브레이크 디스크, 스티어링 휠, 속업쇼바

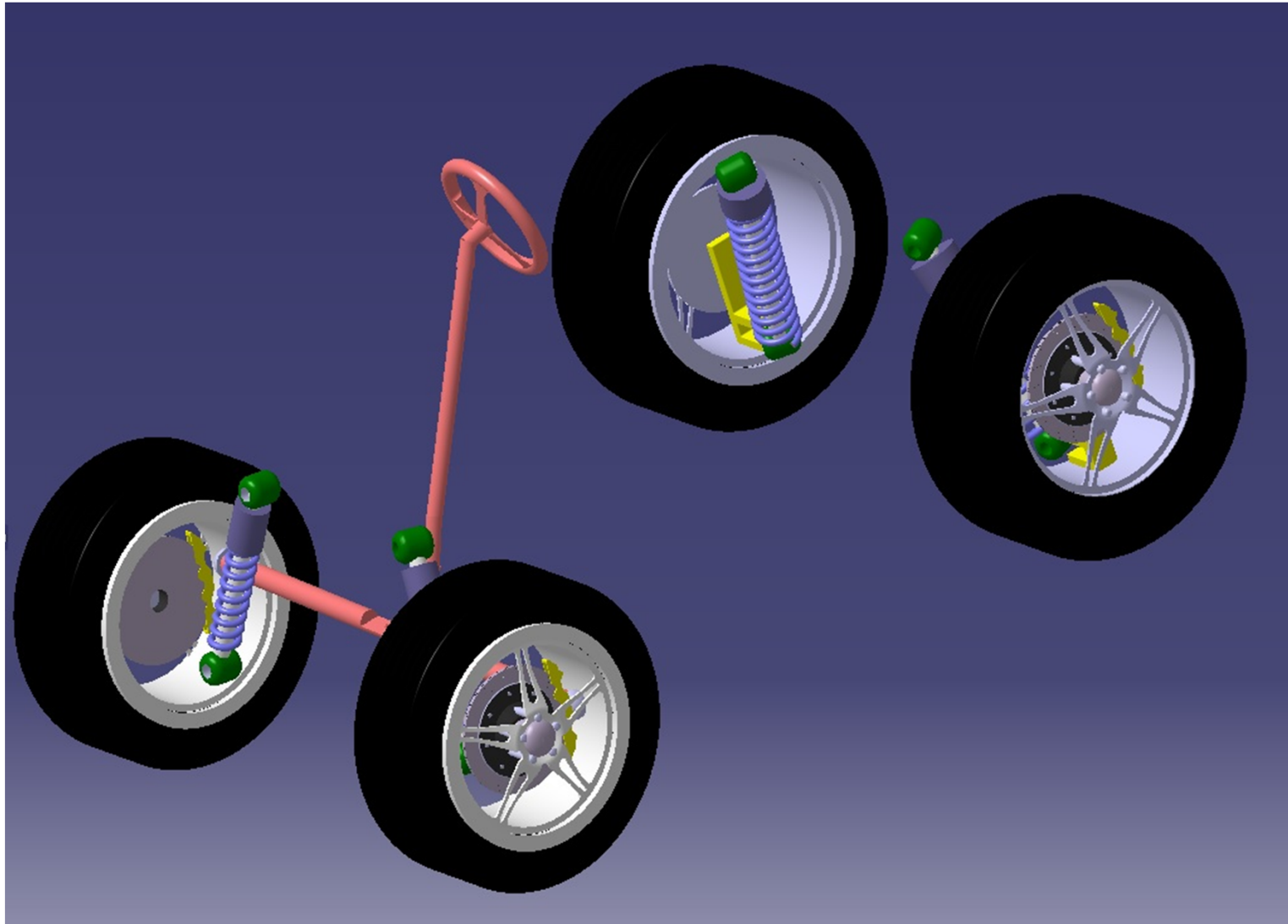

타이어

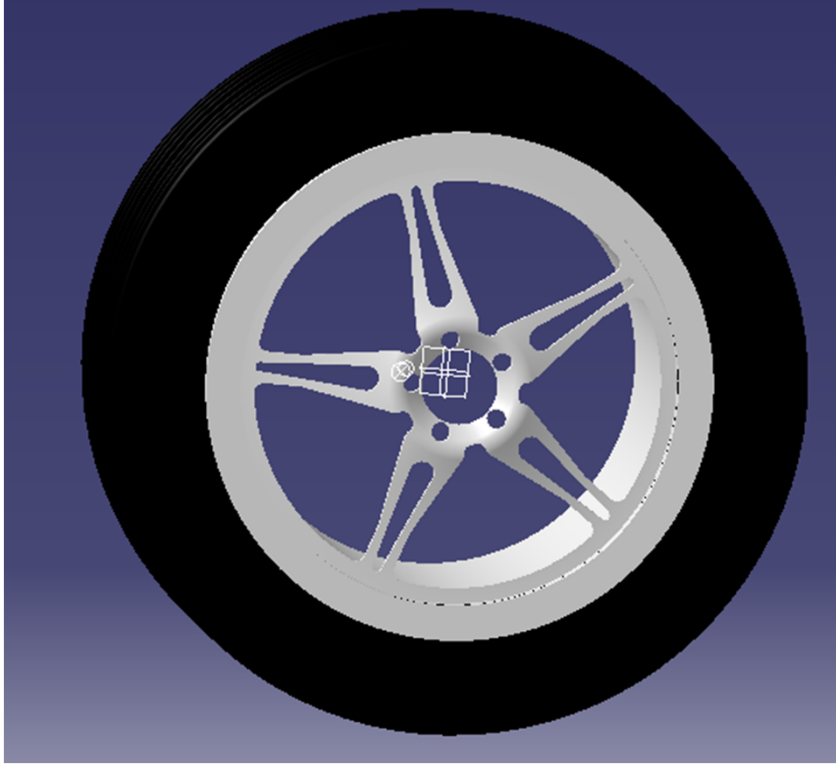

<참고 사진>



브레이크 디스크

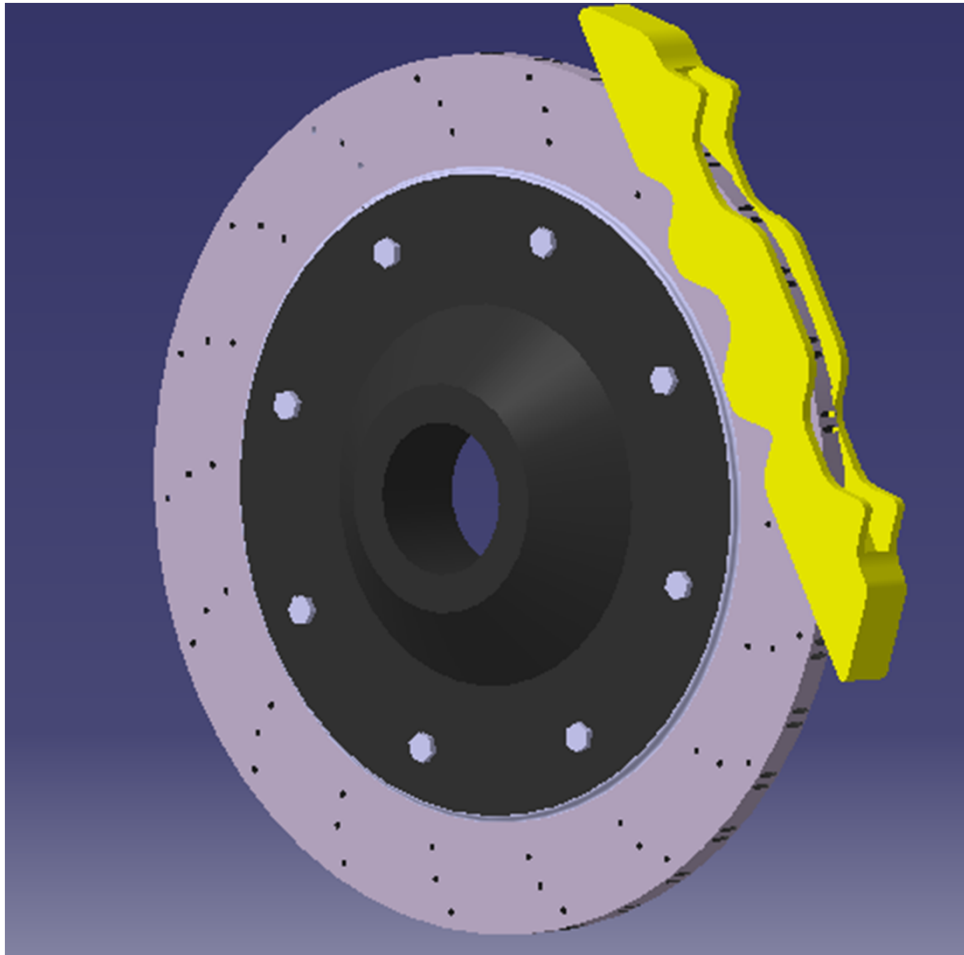

<참고 사진>

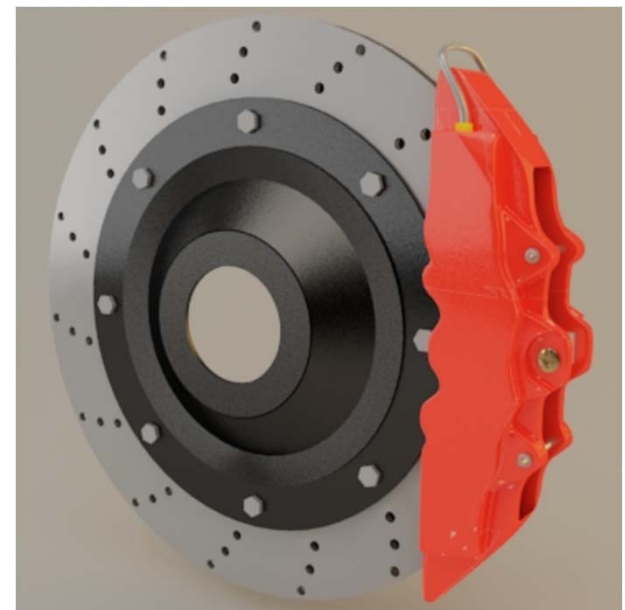

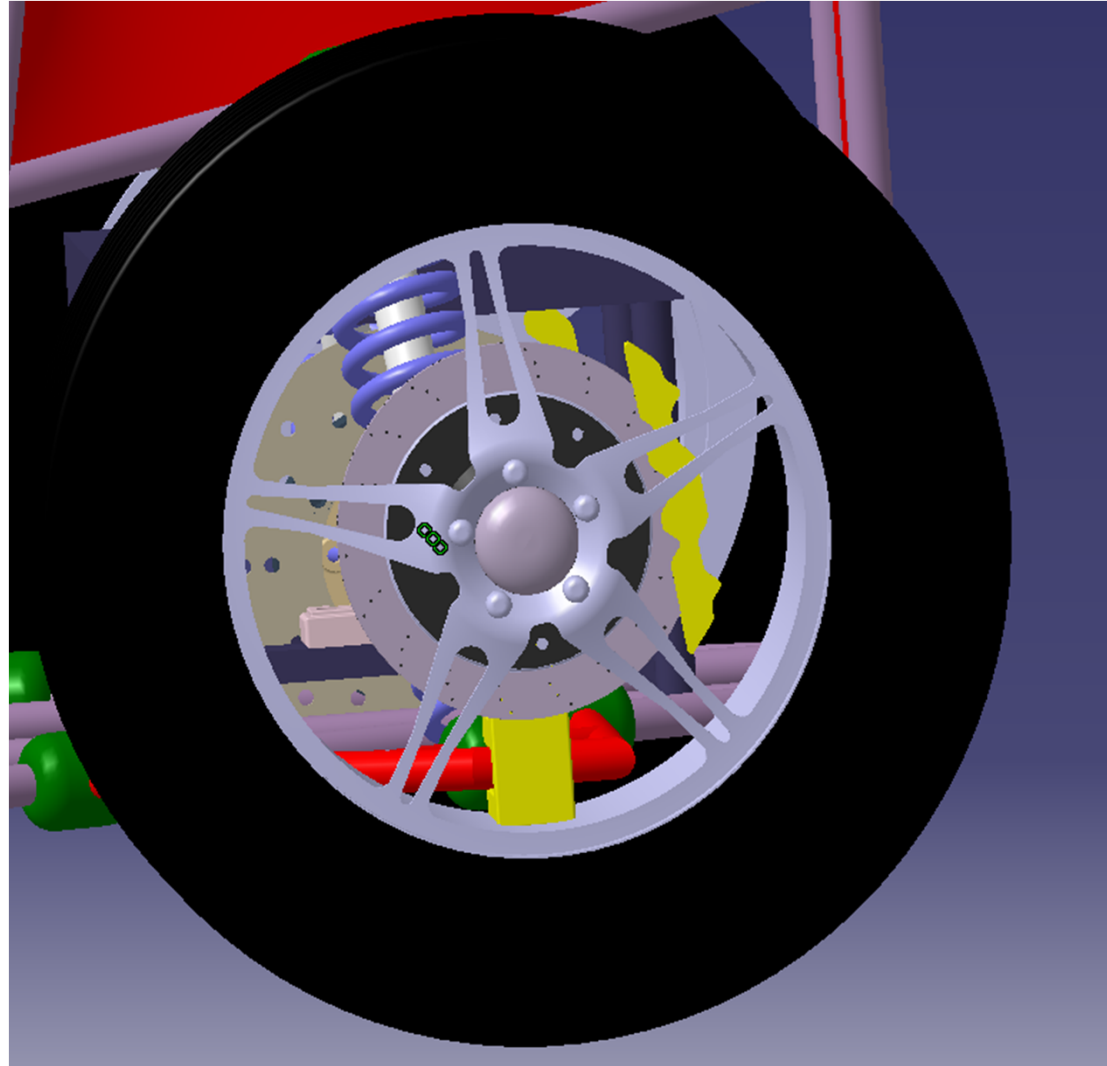

속업쇼바

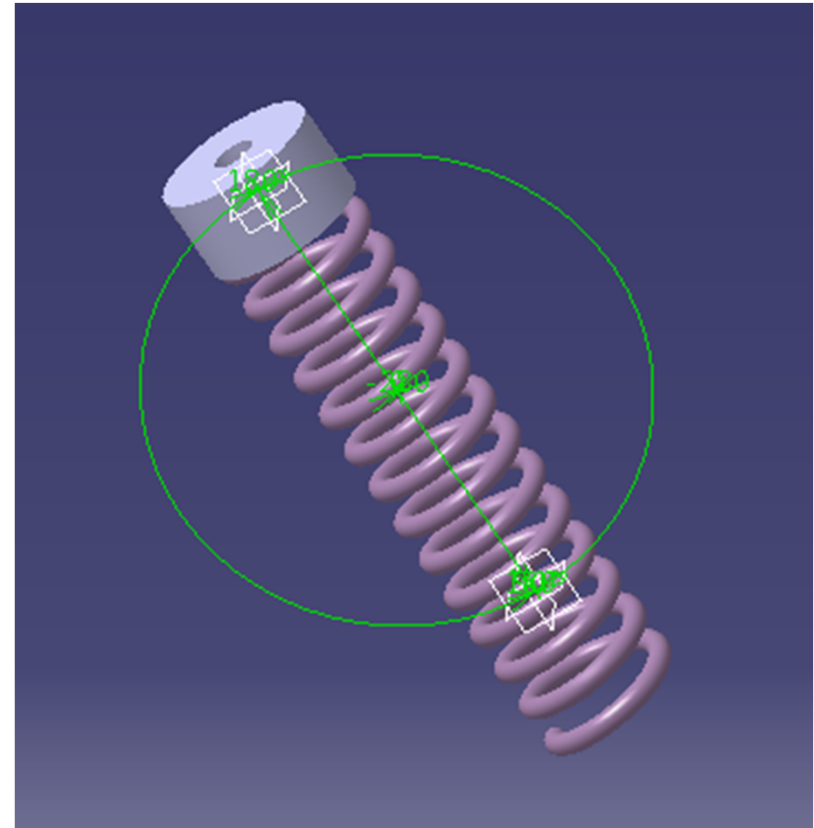
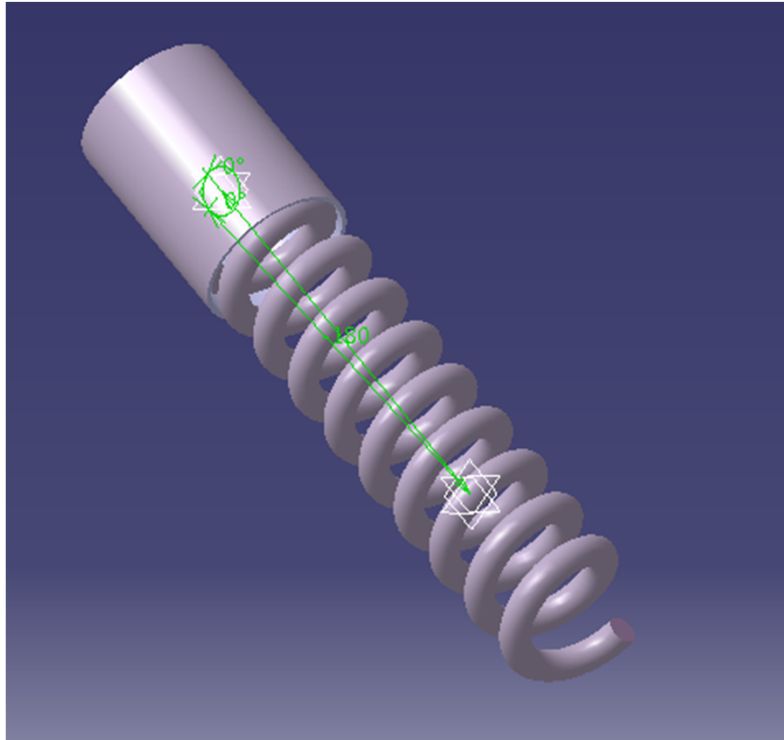

스티어링 휠

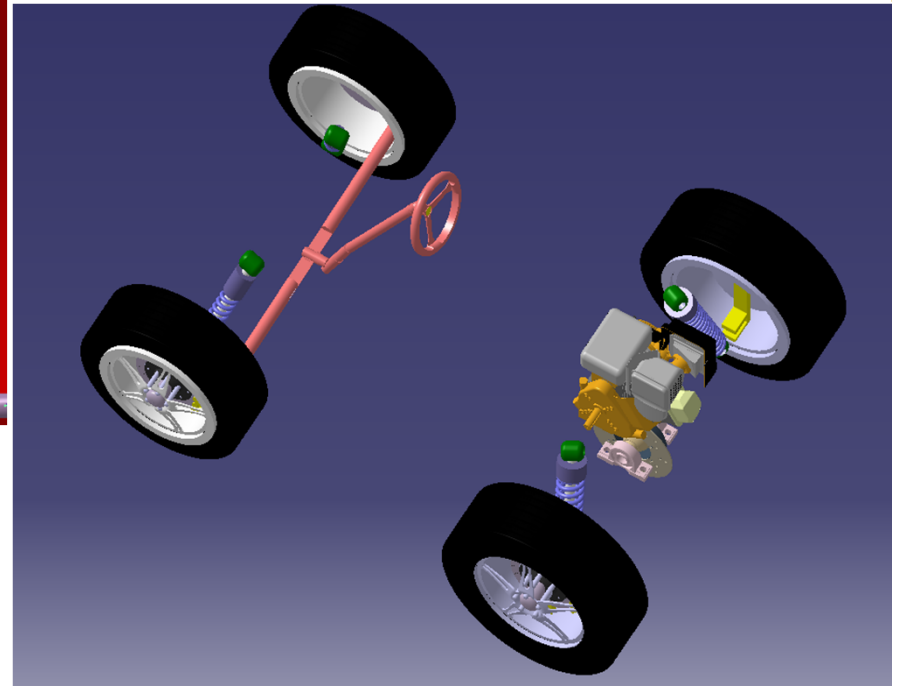
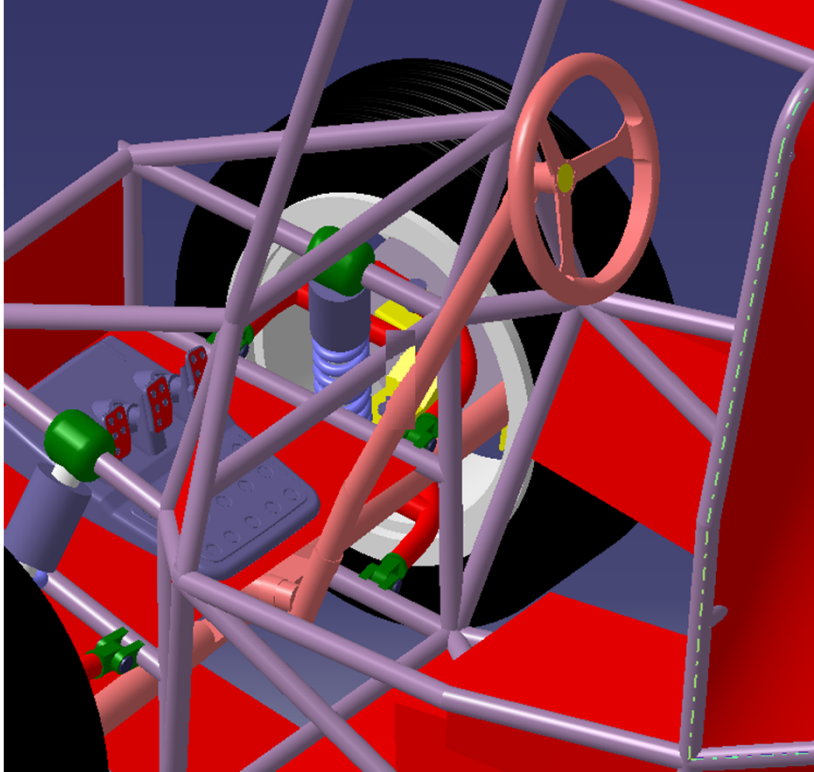

4. 인용한 자료

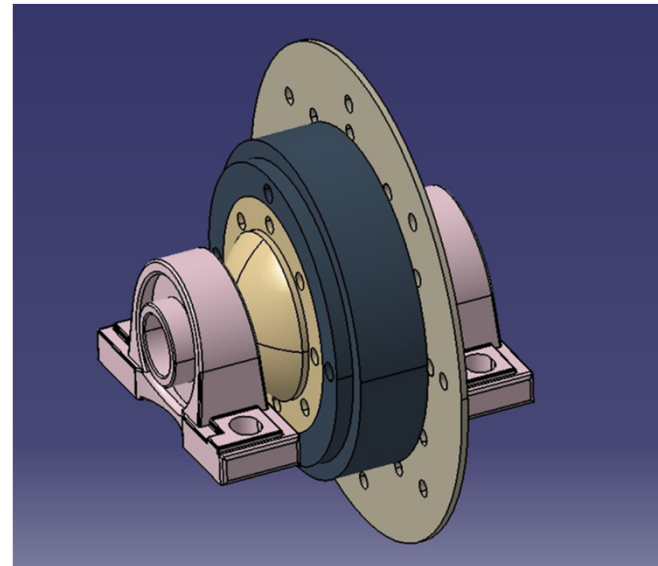
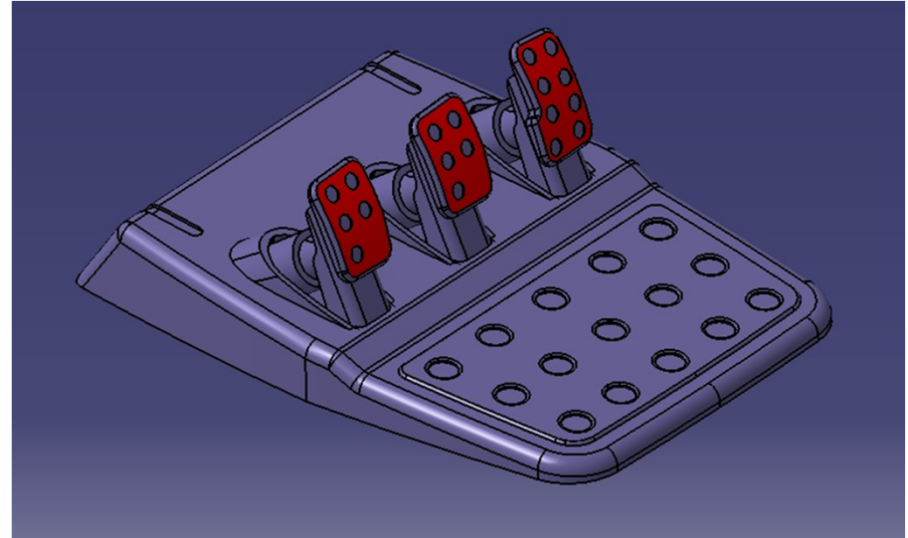
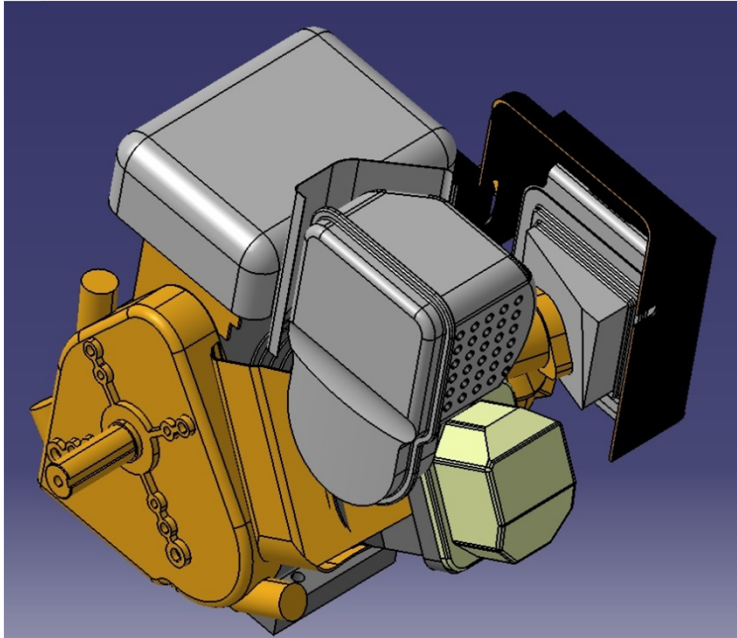

5. 보완해야 할 부분

(1) 조향 장치

