

DRONE



3D's

201401248 김예원
201501263 김성준
20150121 김성준

PROF. MIN SEUNGJAE
2016.06.21 CAD TEAM PROJECT



INDEX

Introduction

- 팀 명 선정 배경
- 주제 선정 이유와 필요성
- 참고 모델

Modeling & Kinematics

- Body
- Propeller
- Wheel
- Gripper
- Camera

Summary

Q&A



Introduction



팀 명 선정 배경

Developer

Drone

3D's ?

C A D

Dimension

Delivery

Introduction



주제 선정 이유와 필요성

WHY
DRONES
왜 지금 드론인가
NOW

편석준, 최기영, 이찬용 지음



취미용에서 군사·상업용까지, 드론의 날렵한 비행은 이미 시작되었다



Introduction



Amazon Prime Air



Introduction



참고모델



Xiaomi Mi Drone Quacopter

(with 4K Camera and 3- axis Gimbal)

Modeling & Kinematics



Body

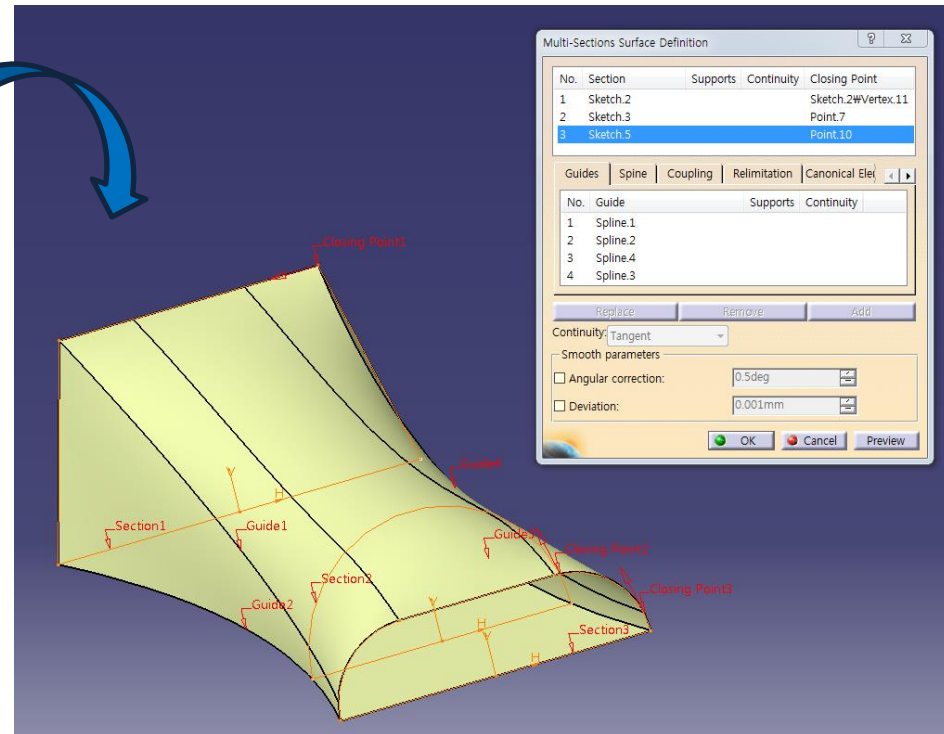
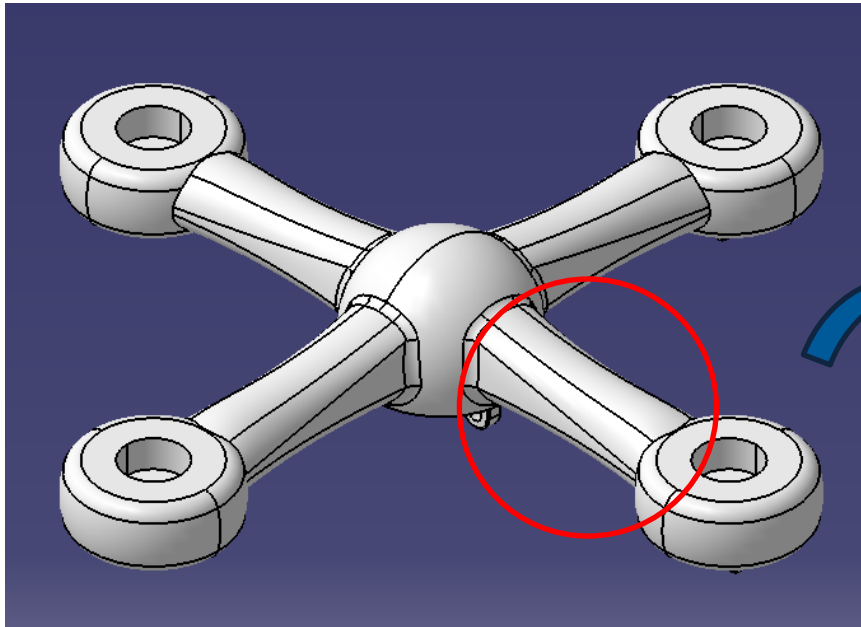

Modeling & Kinematics



Propeller

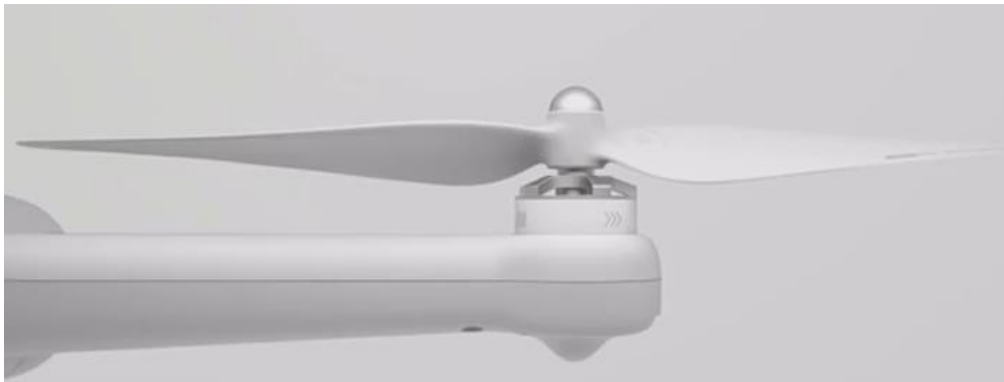

Resource

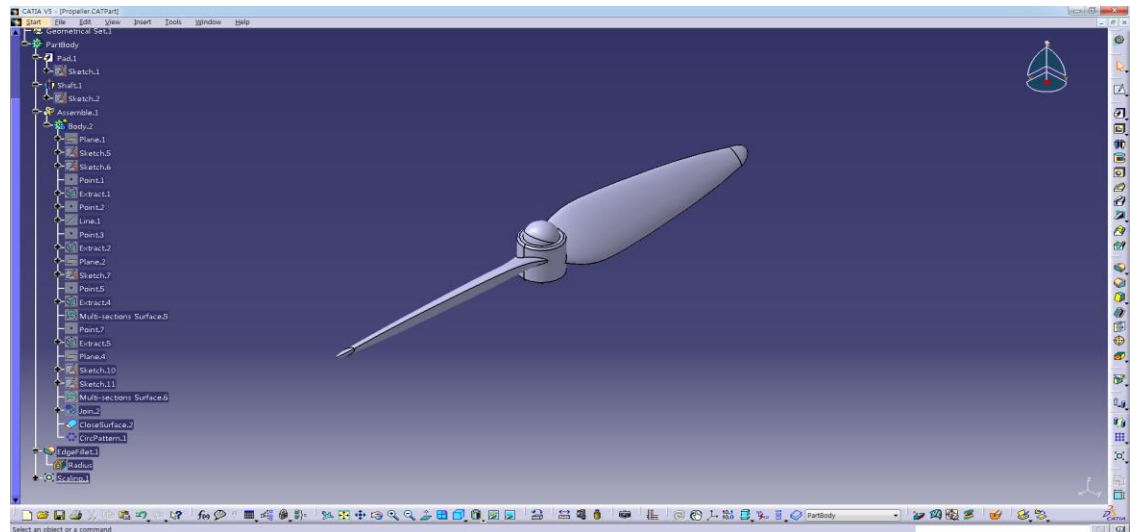

Modeling & Kinematics



Motor (Propeller)

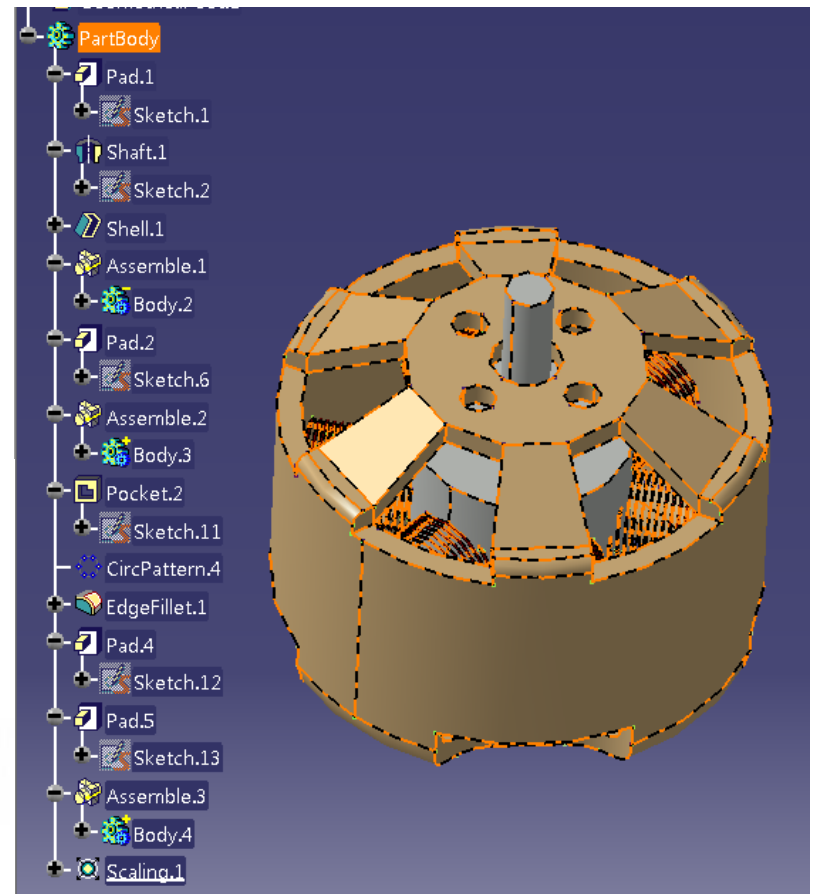

Modeling & Kinematics

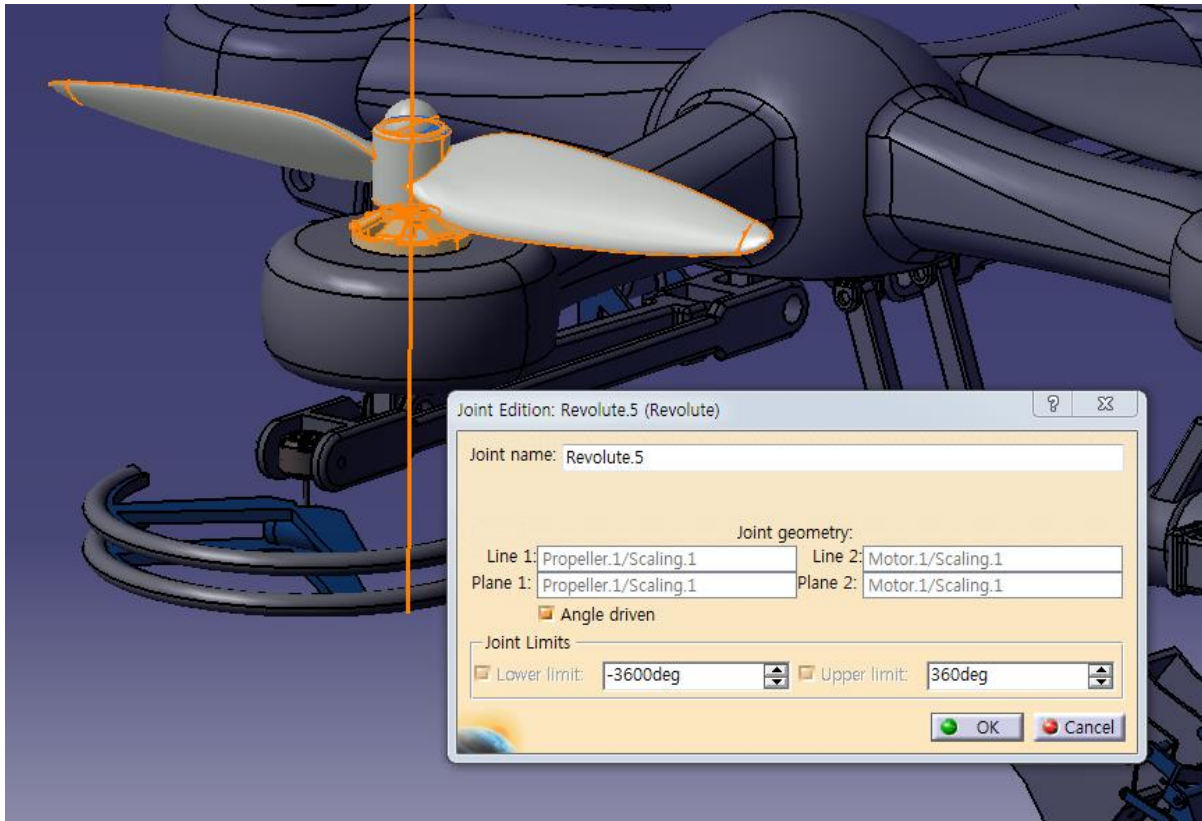

- Revolute.5 (Propeller.1, Motor.1)
- Revolute.6 (Propeller.2.1, Motor.2)
- Revolute.7 (Propeller.2, Motor.3)
- Revolute.8 (Propeller.2.2, Motor.4)

Modeling & Kinematics



Wheel

Resource

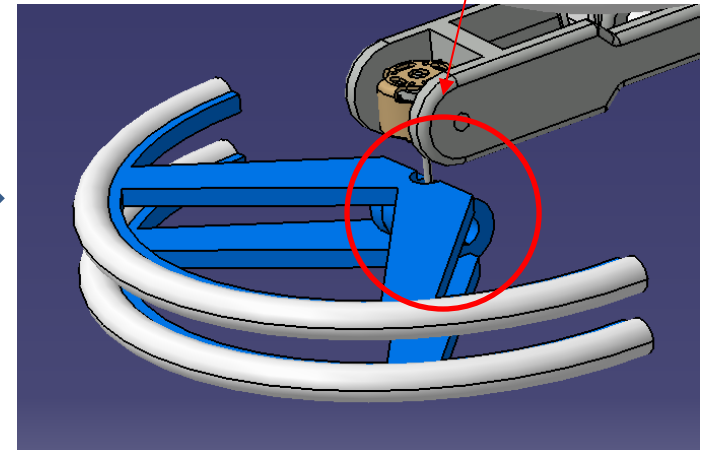
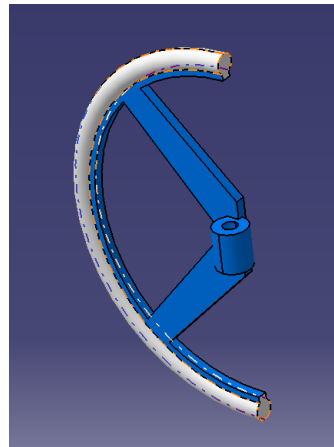
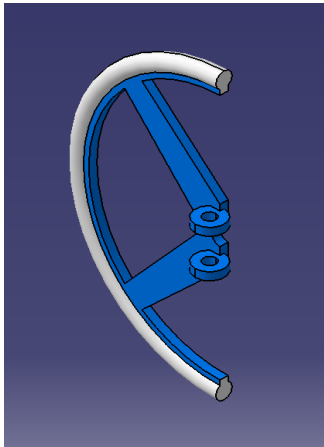
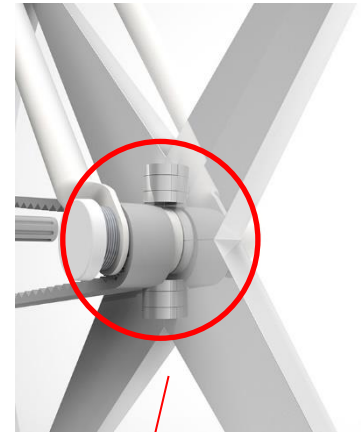

Modeling & Kinematics



- Revolute.9 (Body.1,Bar 1.1)
- Point Curve.10 (Bar 1.1,Bar 2.1)
- Point Curve.11 (Bar 1.1,Bar 2.1)
- Revolute.12 (Body.1,Bar 2.1)
- Revolute.13 (Bar 1.2,Body.1)
- Point Curve.14 (Bar 1.2,Bar 2.2)
- Point Curve.15 (Bar 1.2,Bar 2.2)
- Revolute.16 (Bar 2.2,Body.1)
- Revolute.17 (Motor 0.65.1,Bar 2.2)
- Revolute.18 (Bar 2.1,Motor 0.65.3)
- Revolute.19 (Motor 0.65.1,Tire 2.1)
- Revolute.20 (Tire 2.2,Motor 0.65.3)
- Revolute.21 (Tire 1.1,Tire 2.1)
- Revolute.22 (Tire 1.2,Tire 2.2)

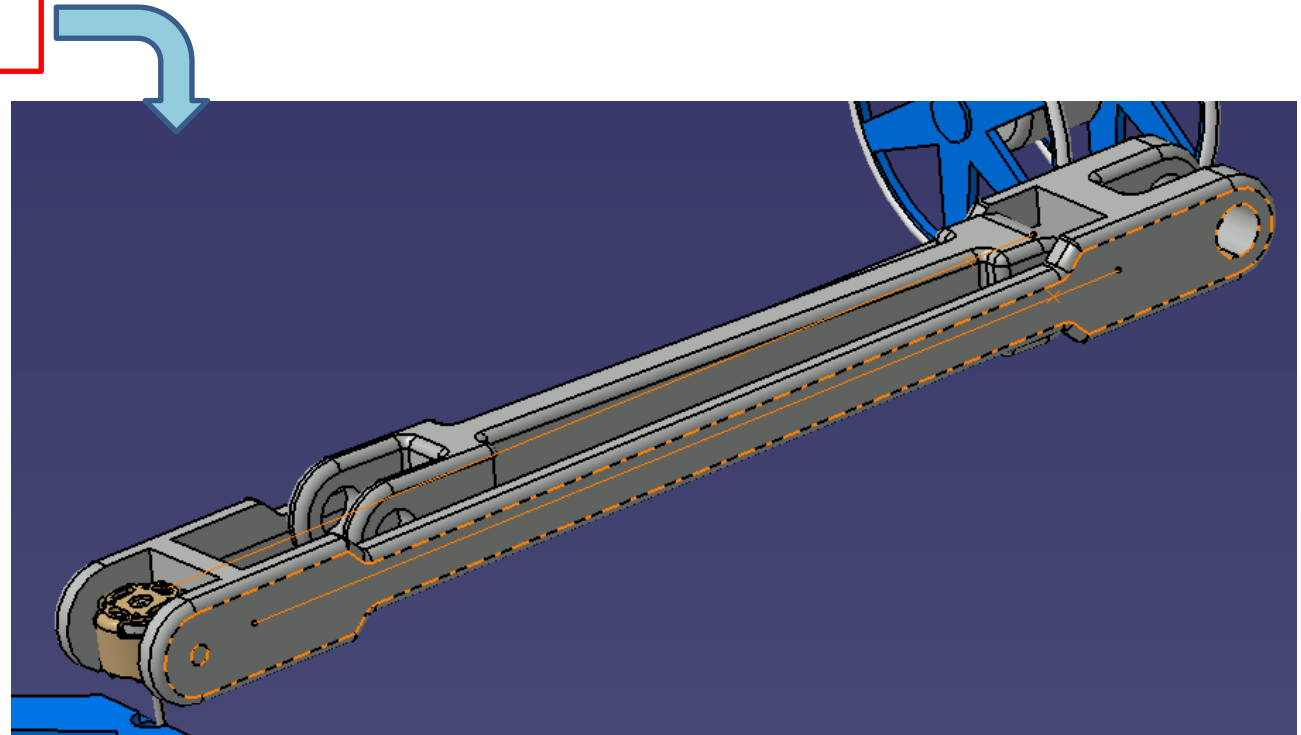

Modeling & Kinematics

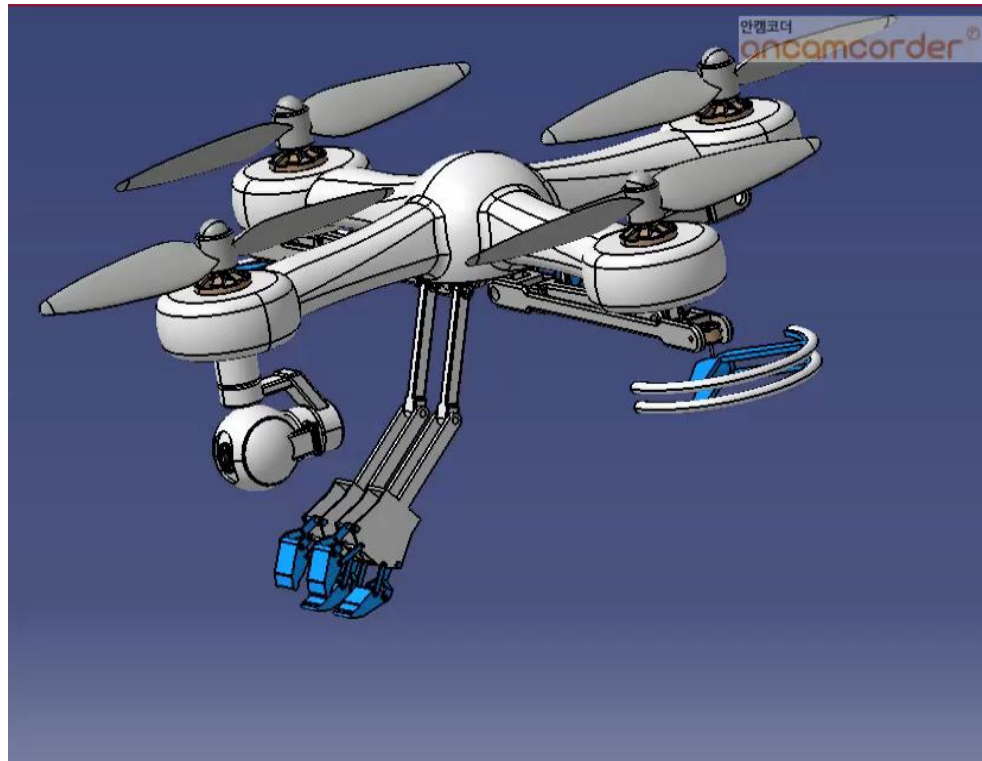

Modeling & Kinematics



Gripper

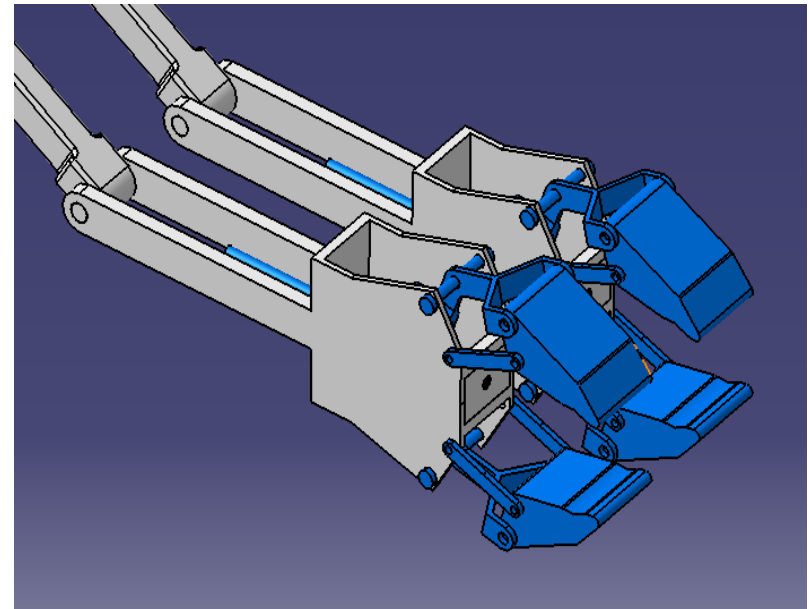
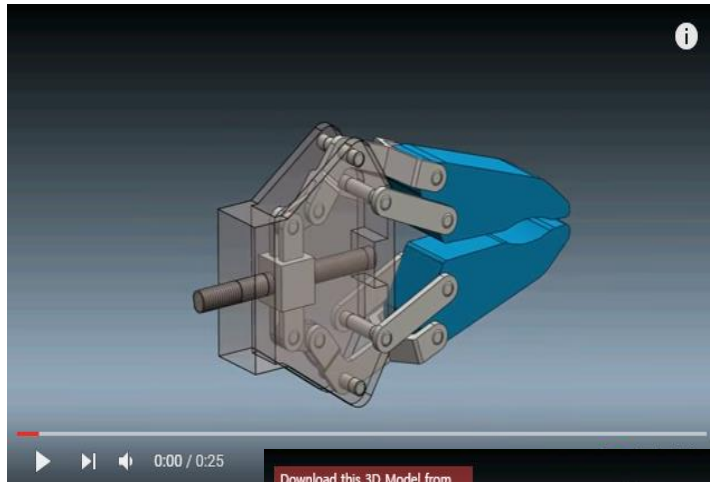

Resource

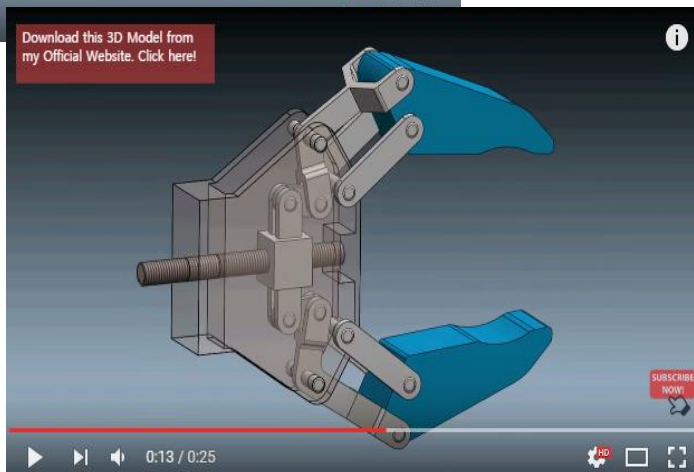

Modeling & Kinematics

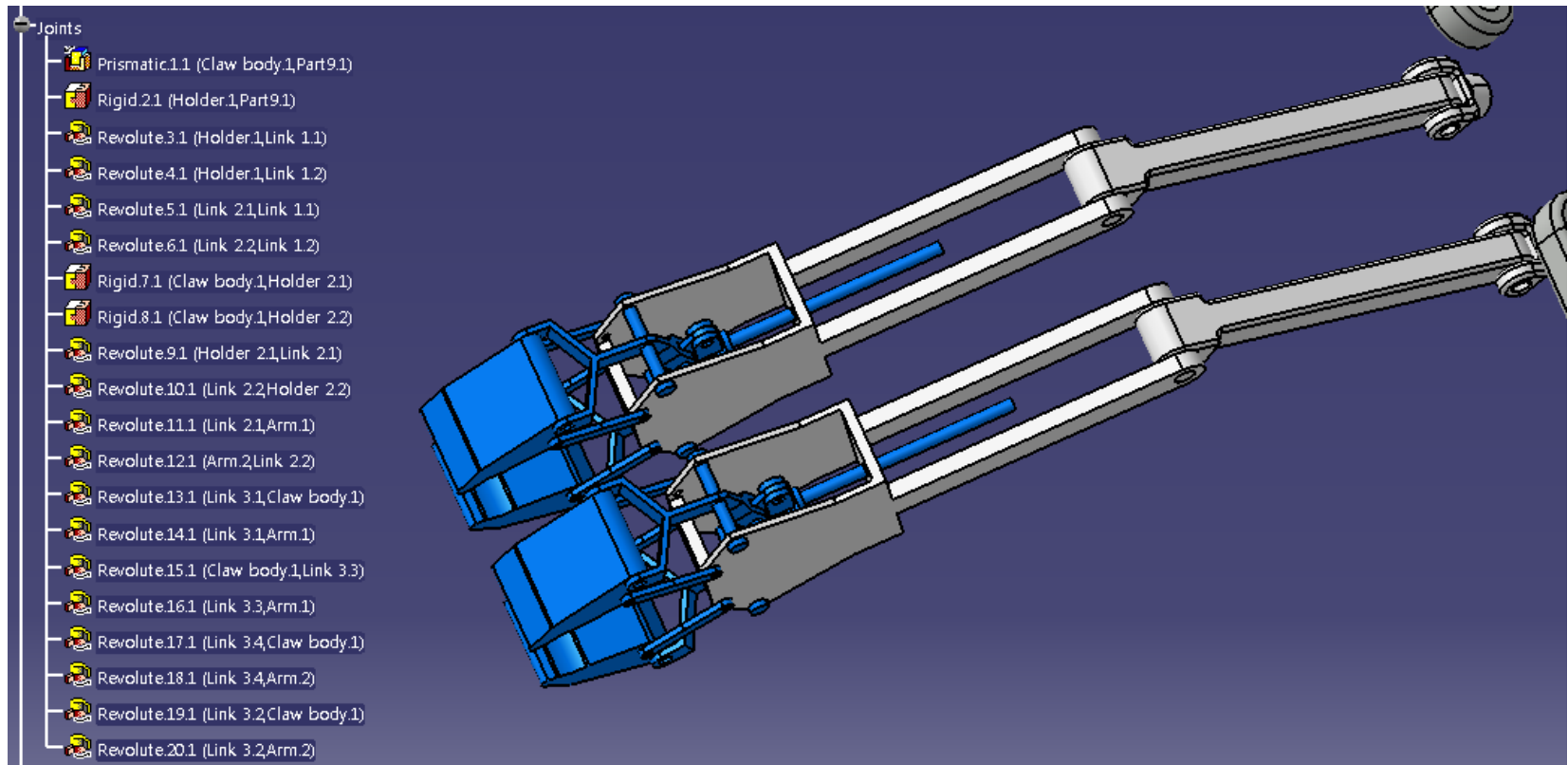

Modeling & Kinematics

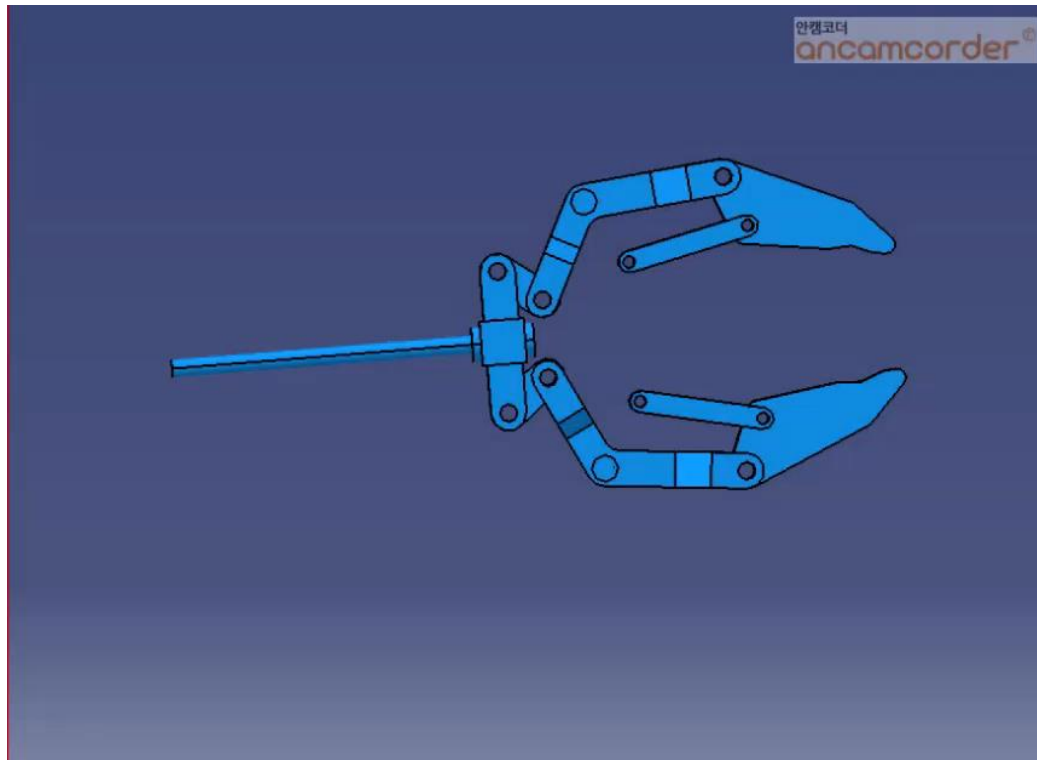

Modeling & Kinematics



Camera



Resource

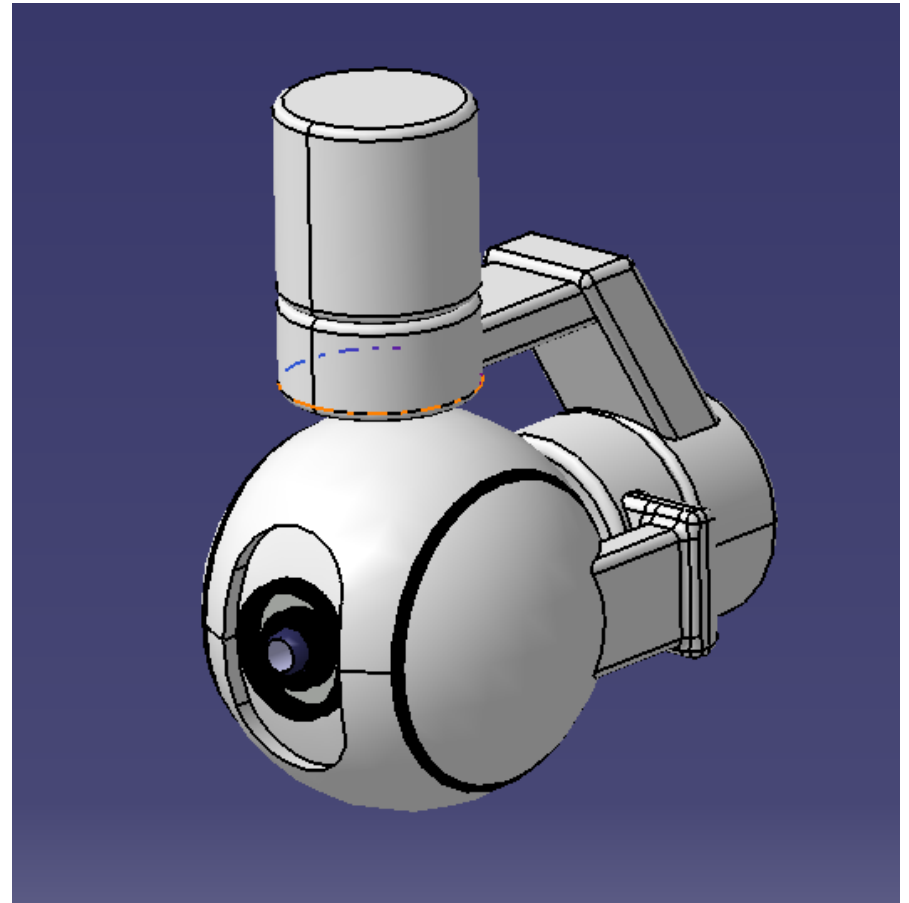

Modeling & Kinematics



Revolute 24

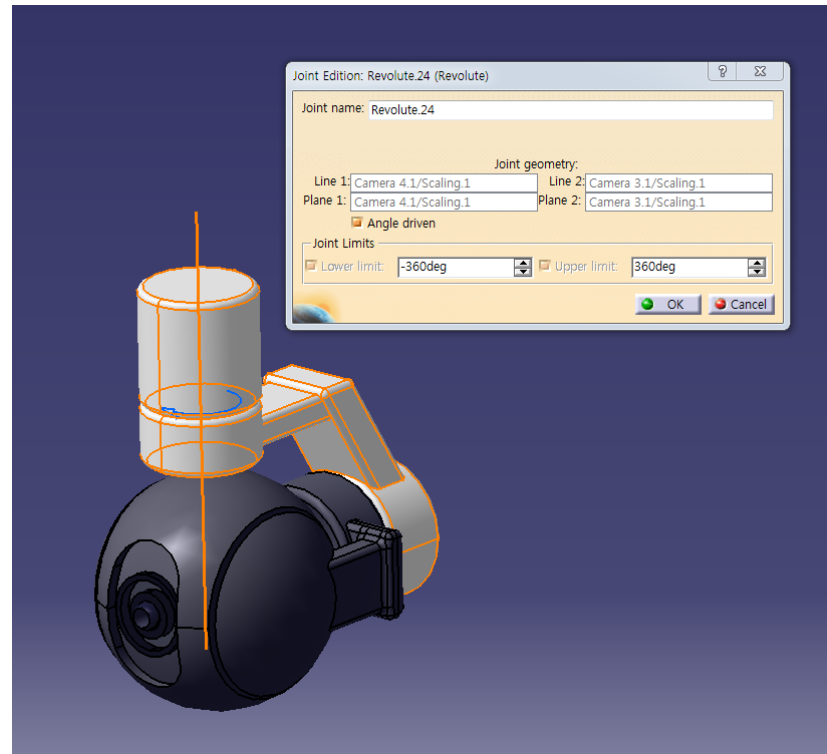

Modeling & Kinematics

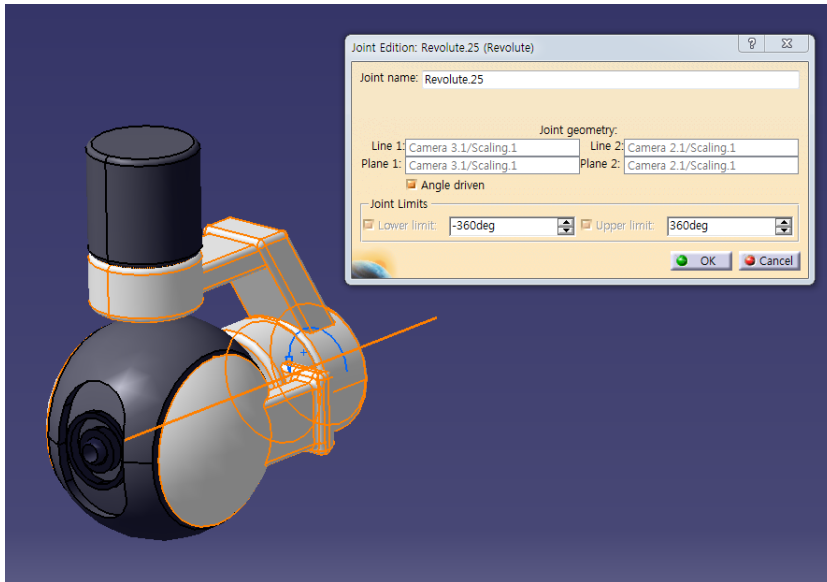

Revolute 25

Revolute 26

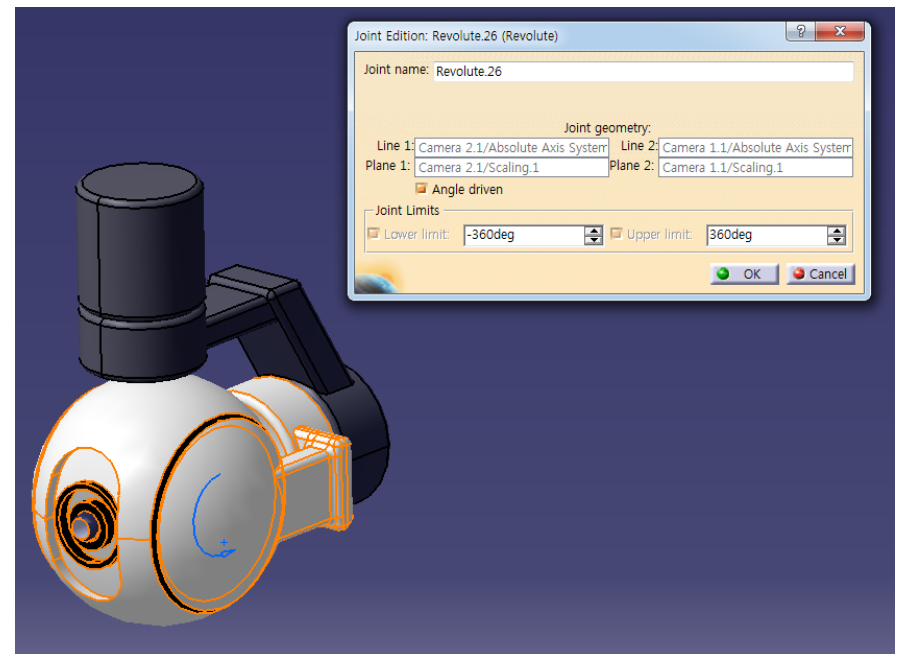

Modeling & Kinematics

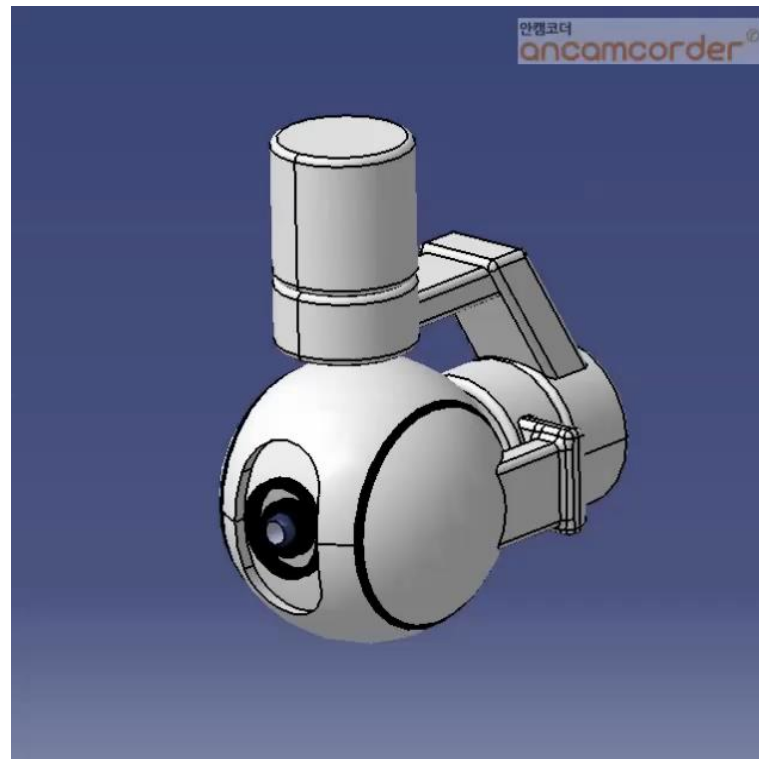

Summary

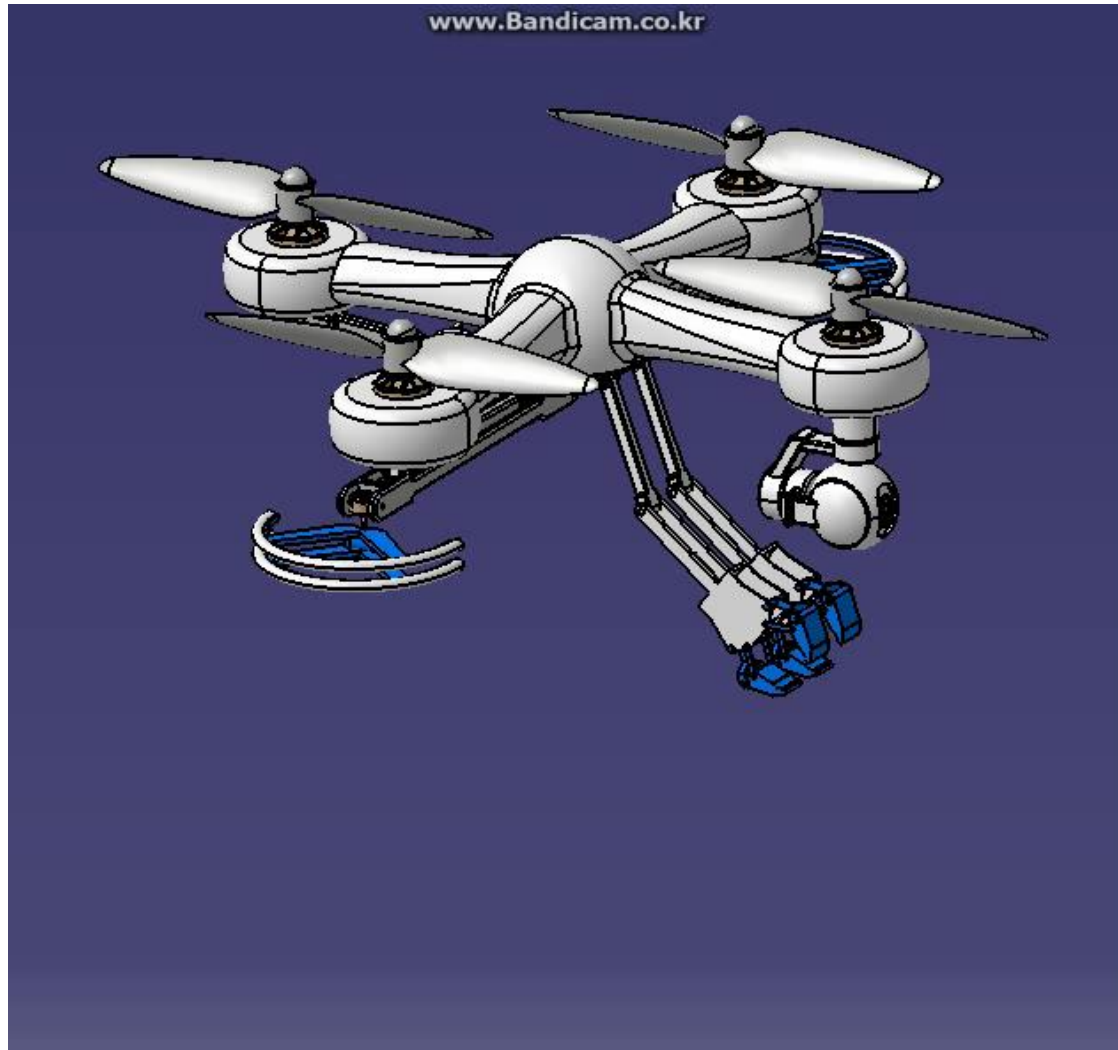

Summary



DRONE



Q&A