

인류의 우주 진출을 위한 아이디어

Team, **Stephen Docking**

김대용 2015012606

김찬 2015012697

이동수 2015012788

Contents

01 팀 명 소개

06 Camera

02 주제 선정 배경

07 아쉬운 점

03 영상 시연

08 Q & A

04 아이디어

05 모델링 과정



1

팀 명 소개

Stephen Docking

01 팀 명 소개

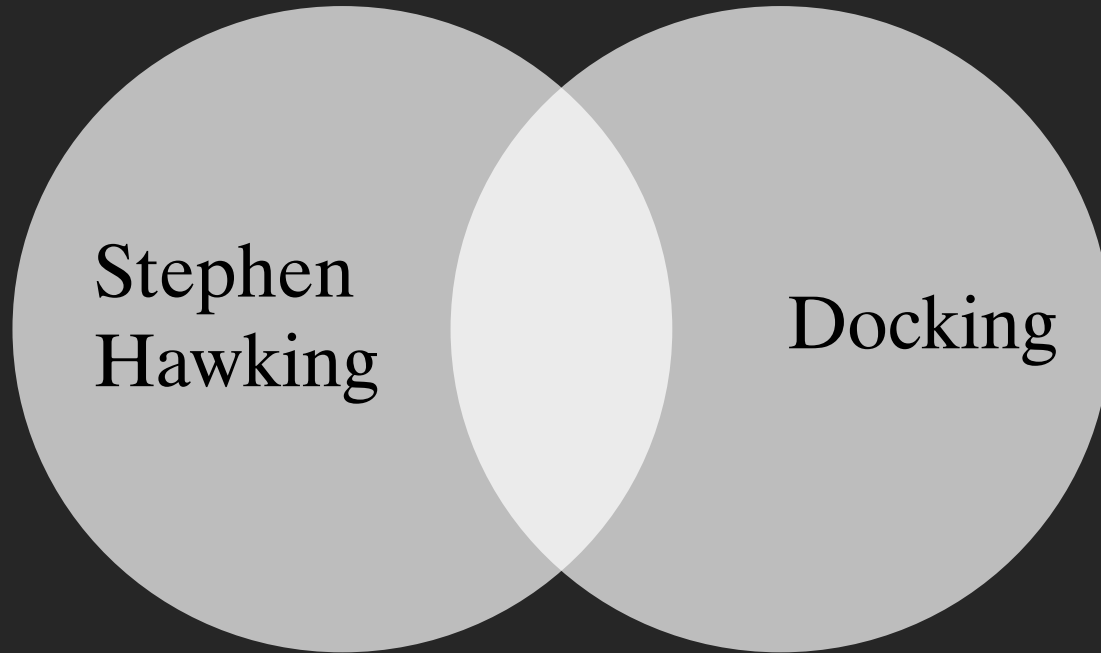



2

주제 선정 배경

Stephen Docking

02 주제 선정 배경

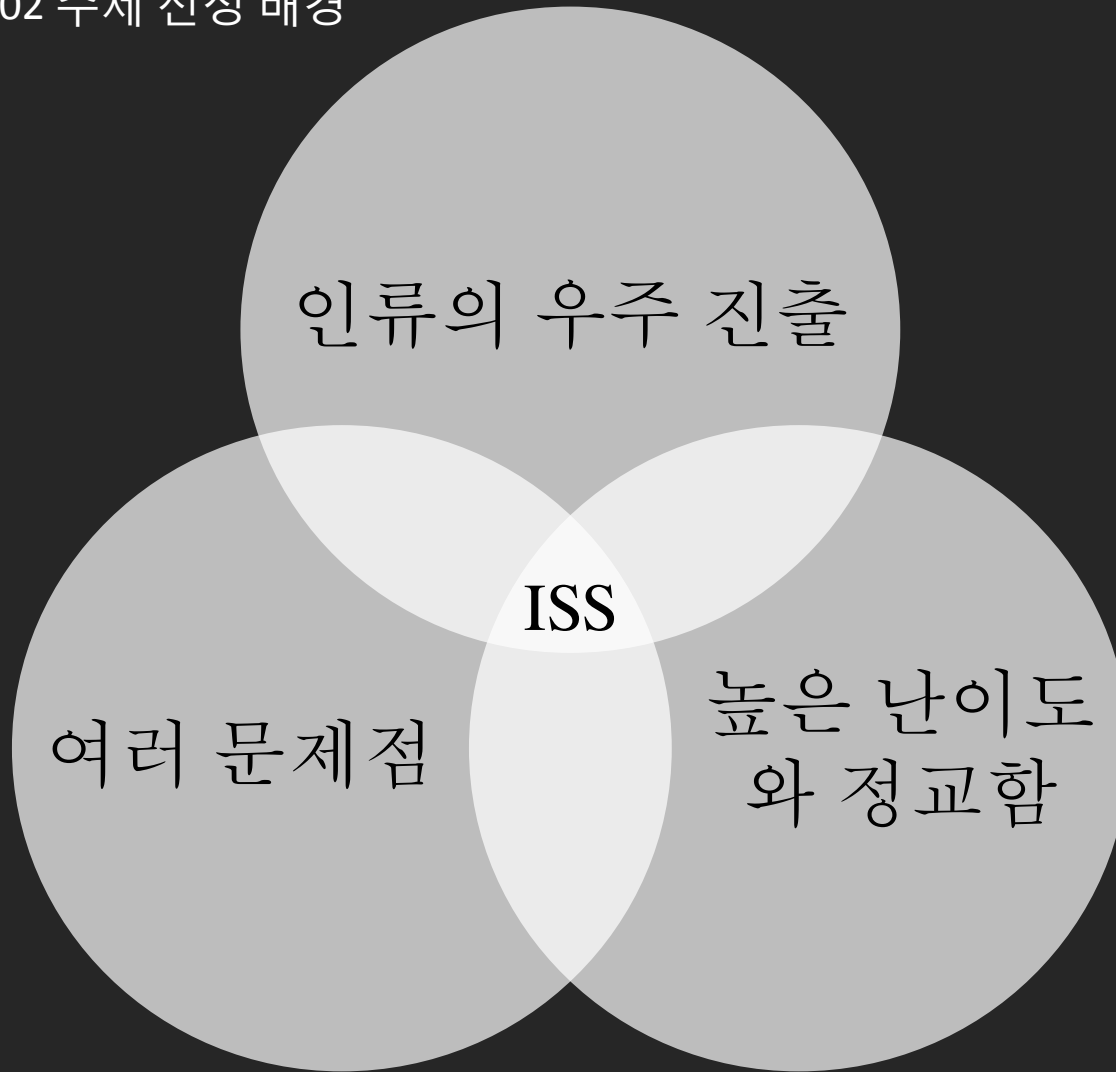



3

영상 시연

Stephen Docking



CATIA ISS & Saturn V docking + kinematics video
<https://youtu.be/aGL7tuBIF8I>



4

아이디어

Stephen Docking

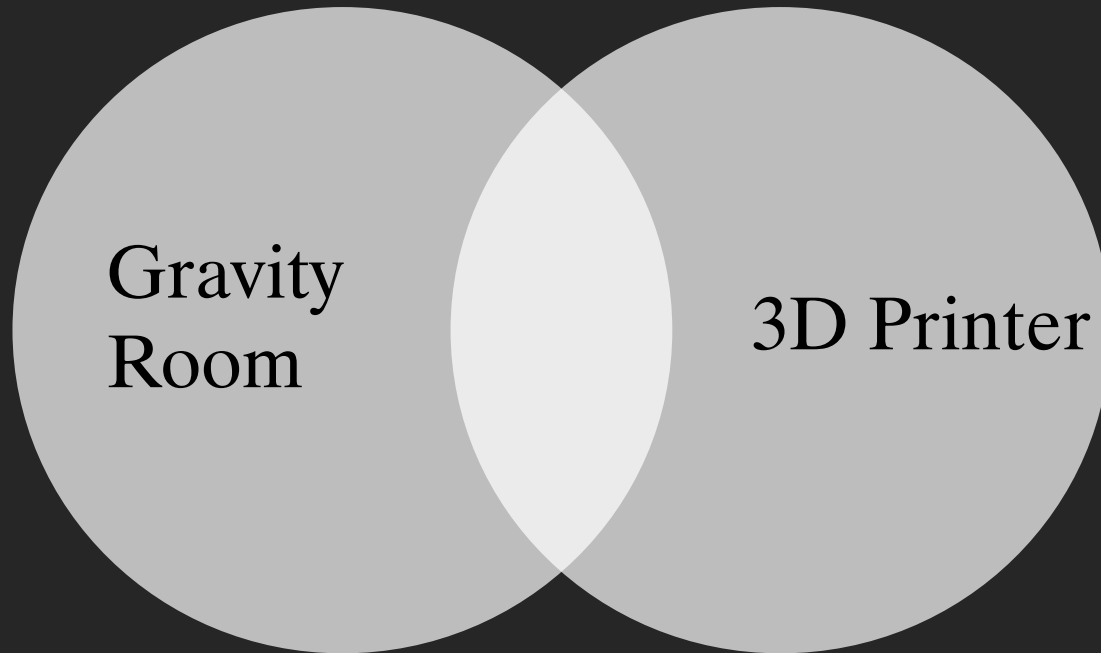

04 아이디어

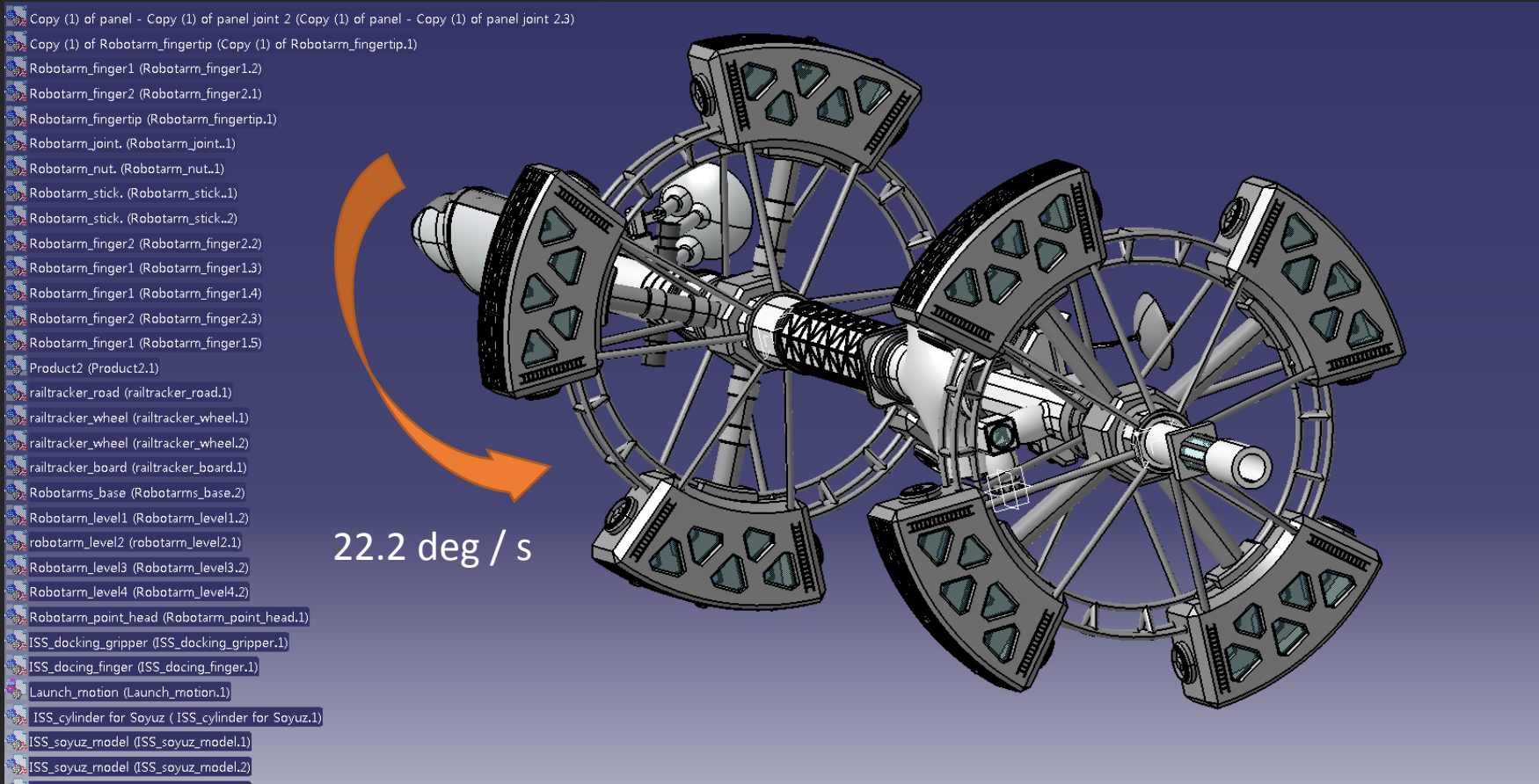

350 feet : 3800 mm = 1m : 35.6 mm

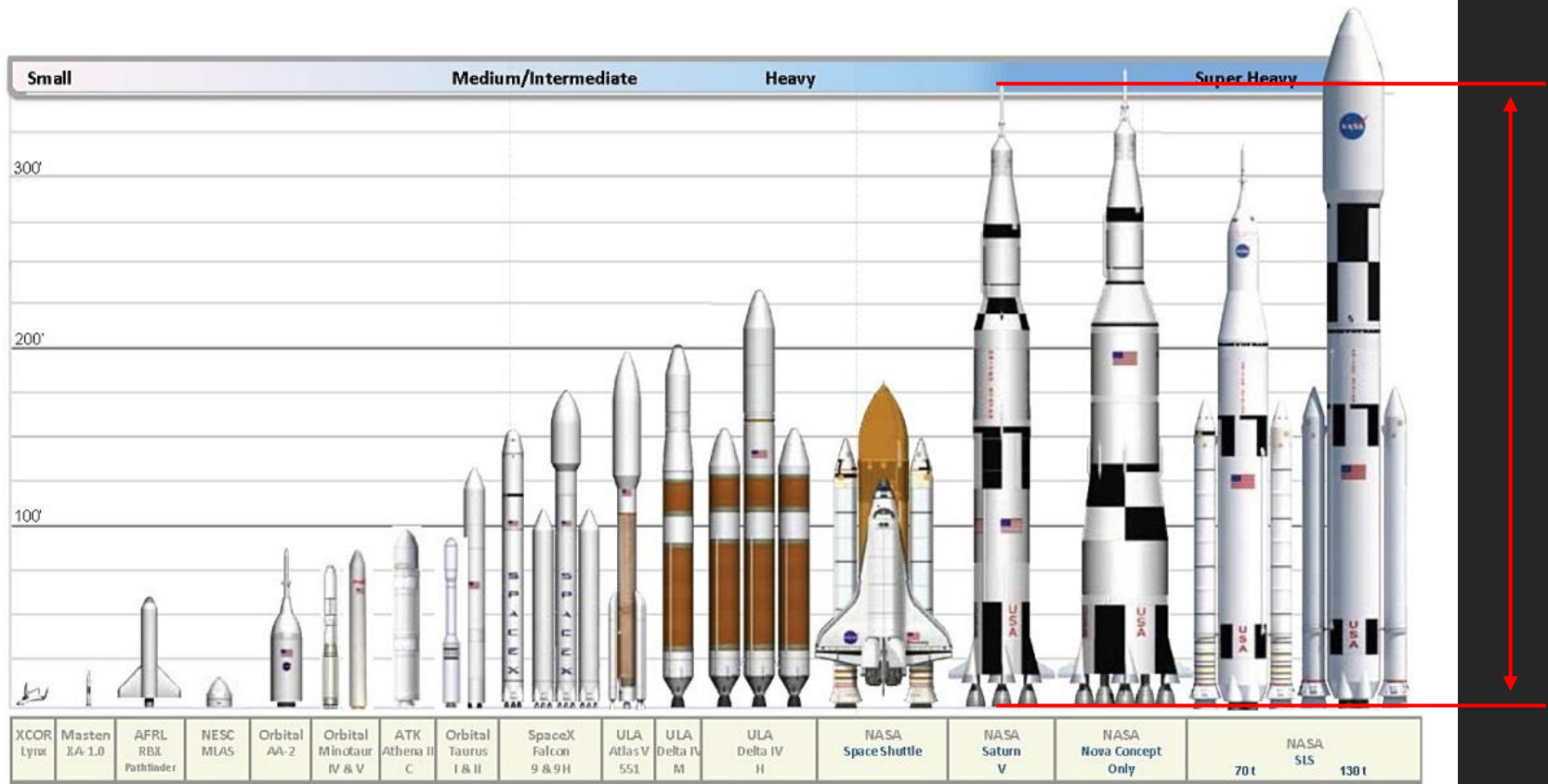

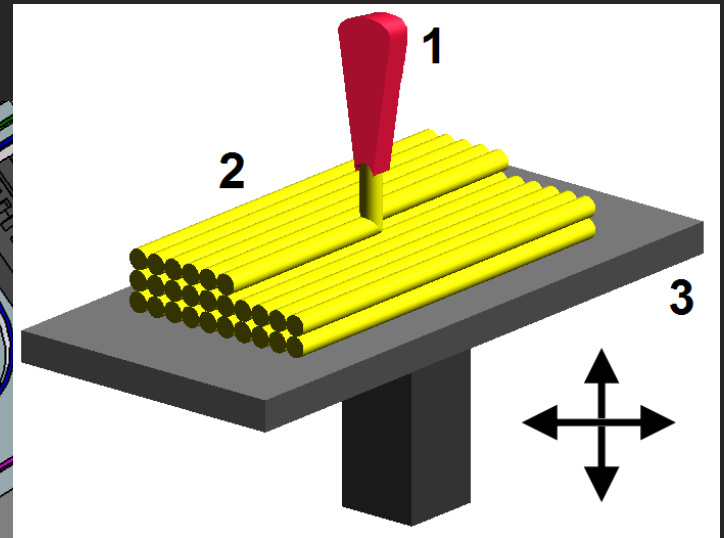
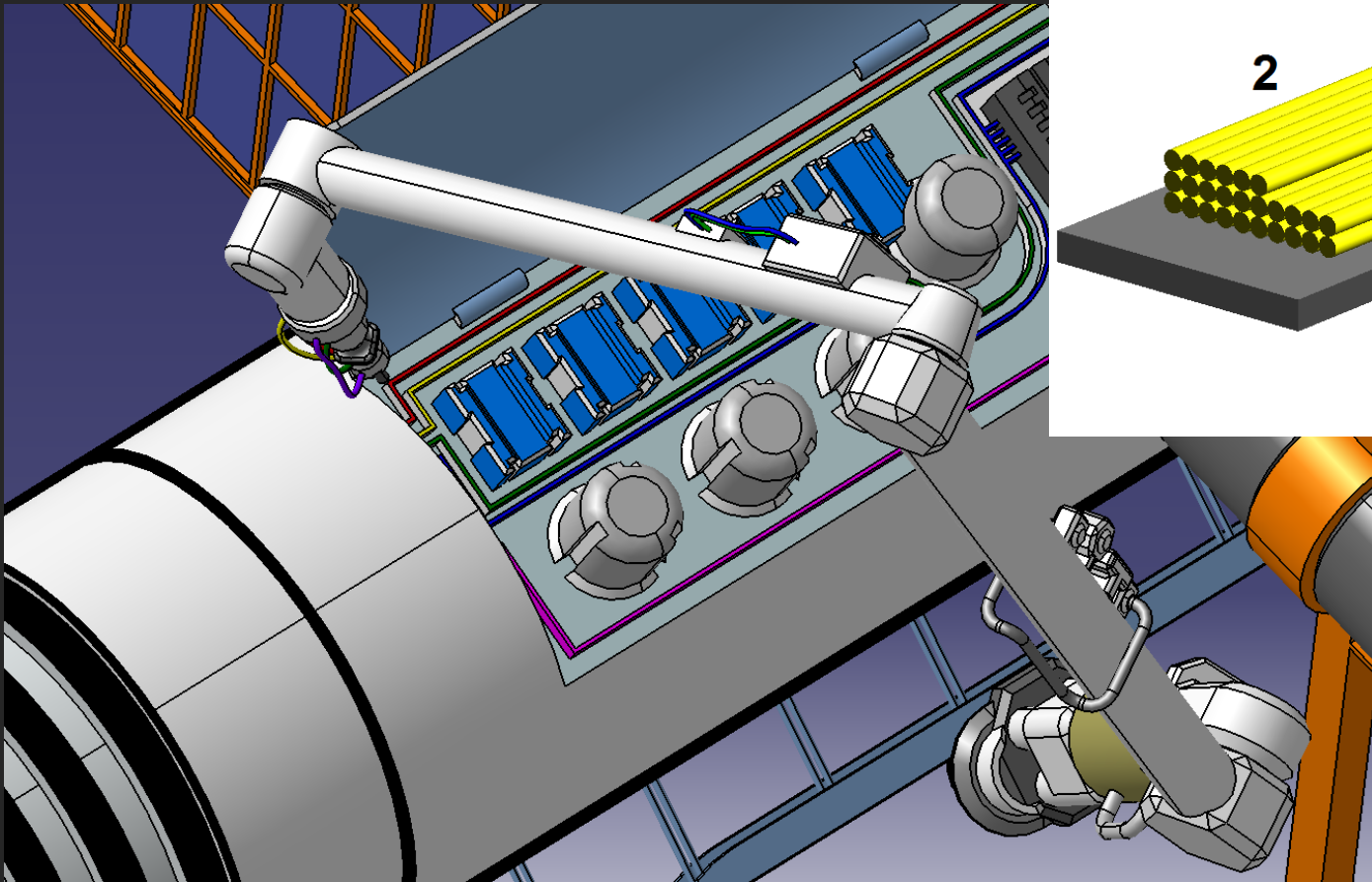

FDM



5

모델링 과정

Stephen Docking



Saturn V 외
형 디자인

05 모델링 과정



05 모델링 과정

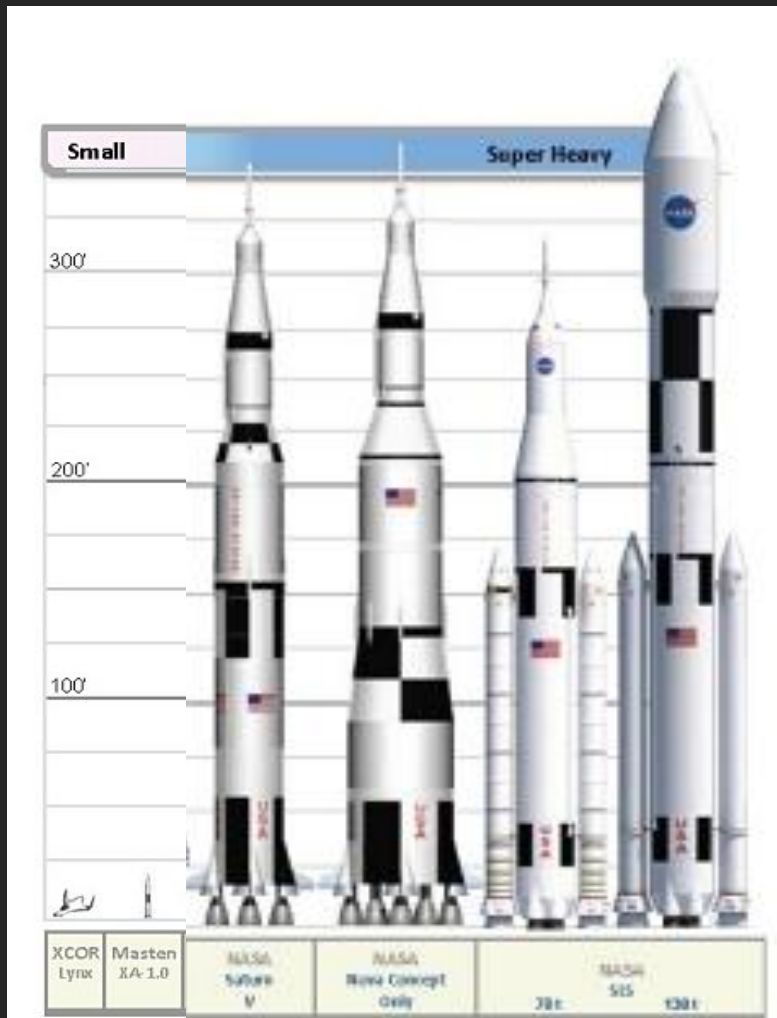



Saturn V 엔진
디자인

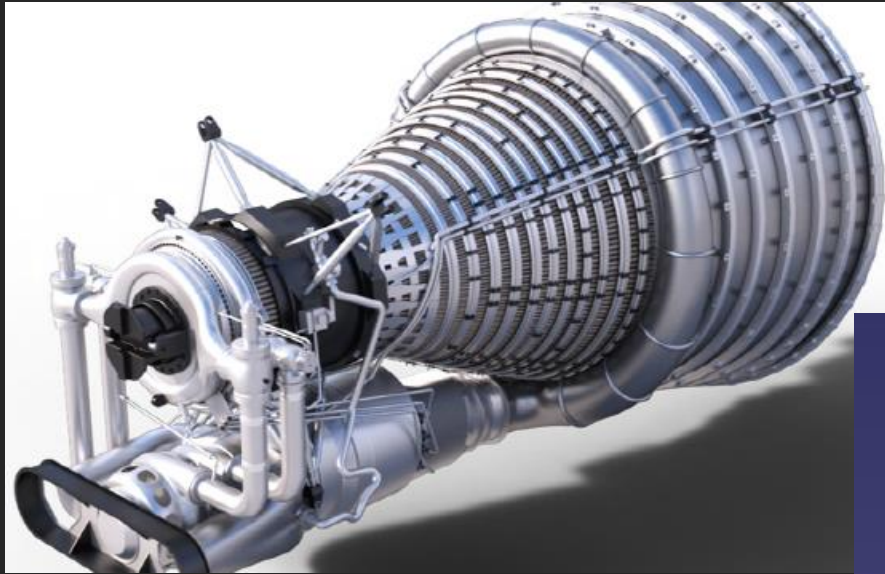

F-1

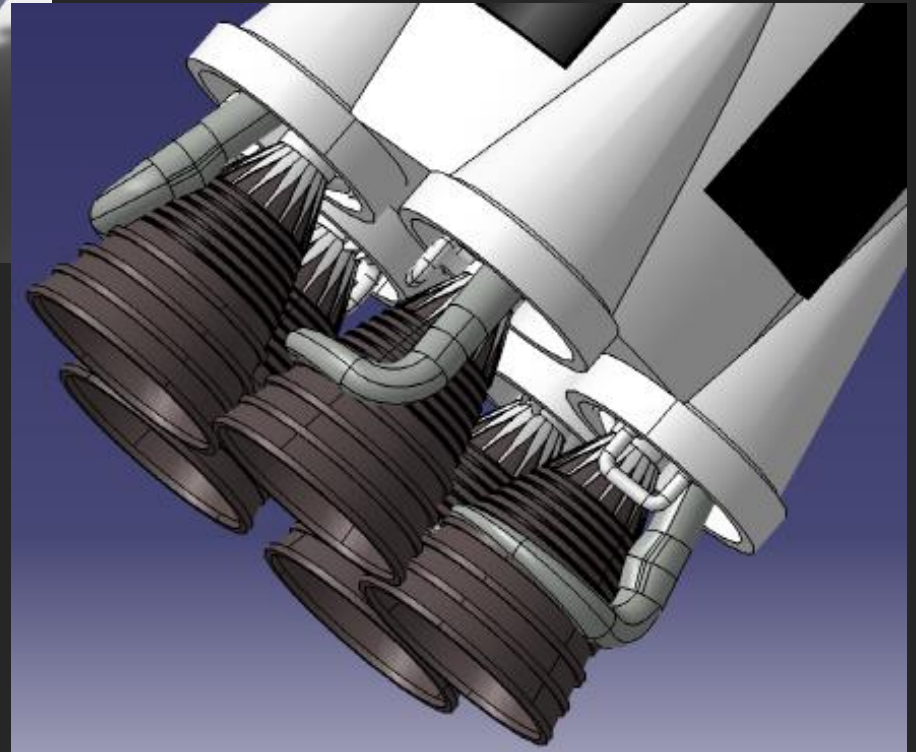

First
Engine



J-2

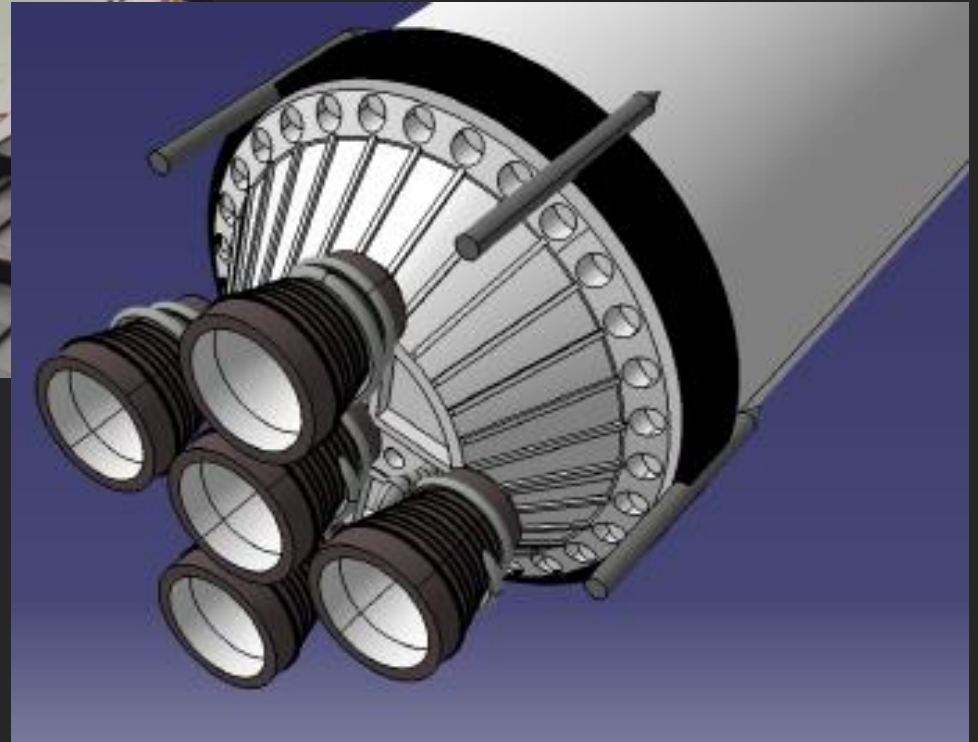

Second
Engine

J-2 (advanced)

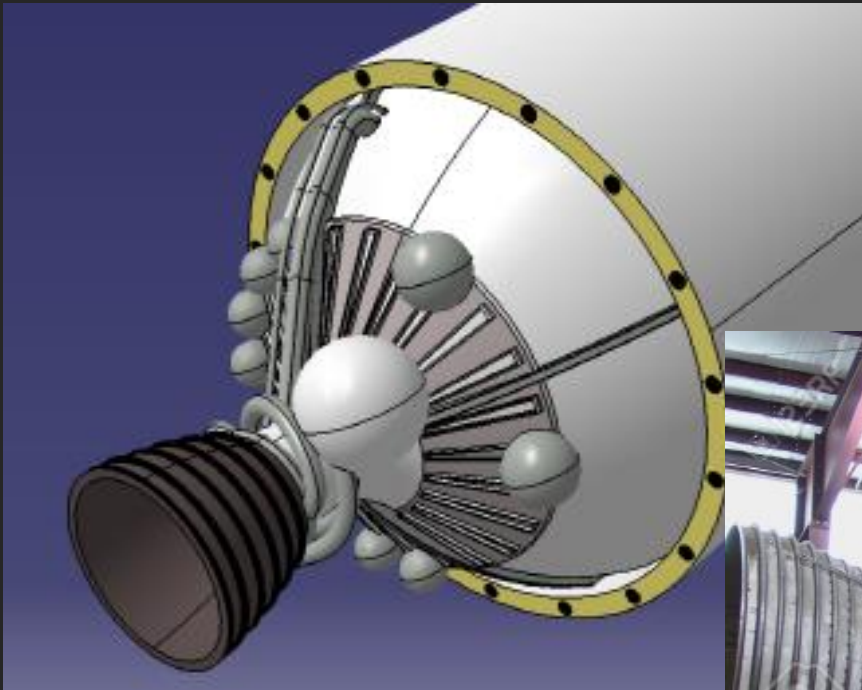

Third
Engine



ISS 디자인

05 모델링 과정

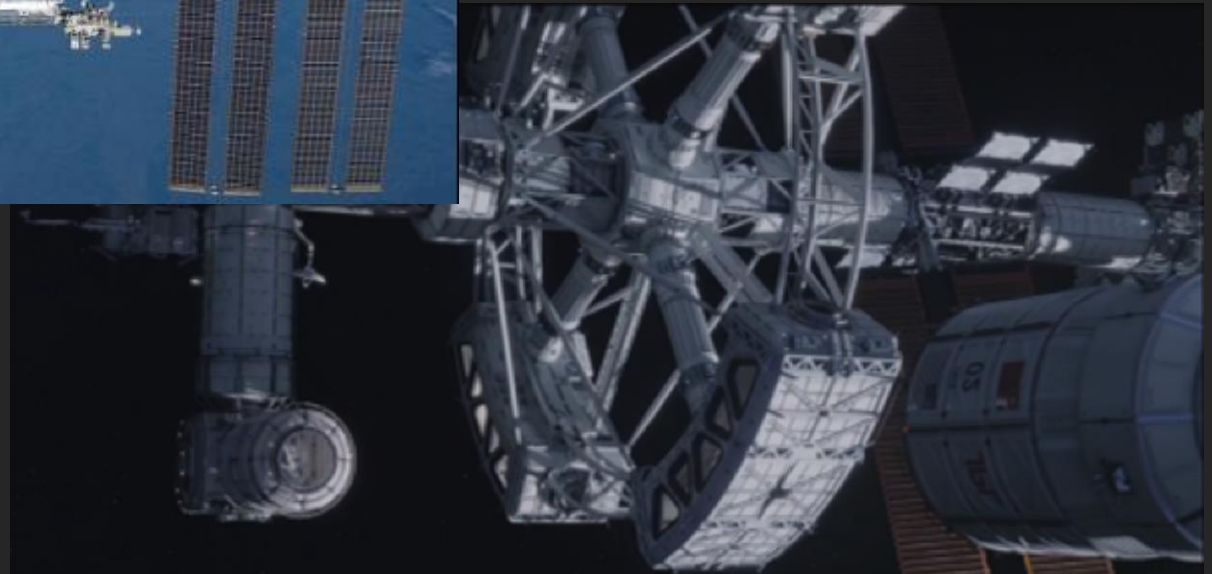

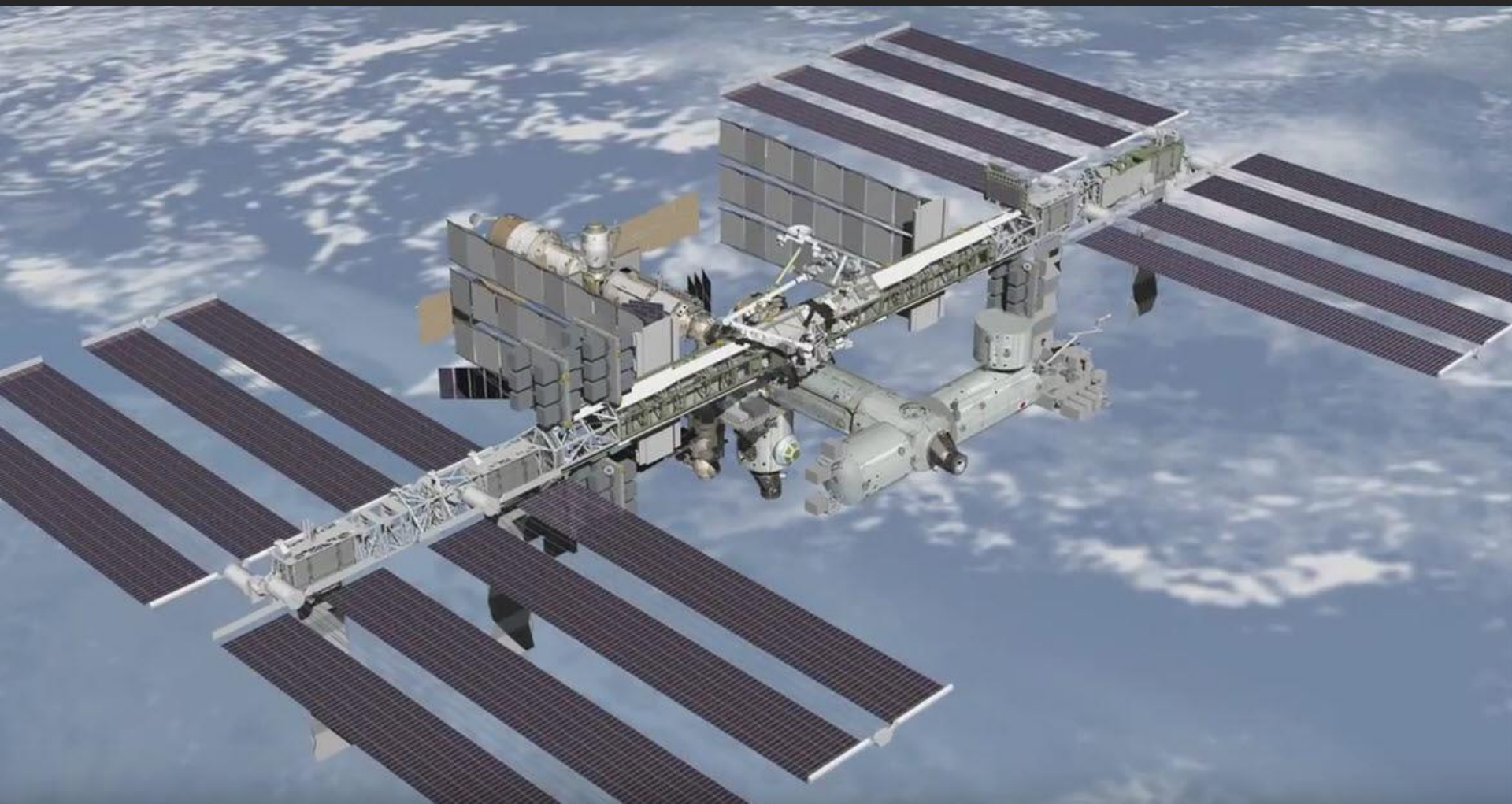

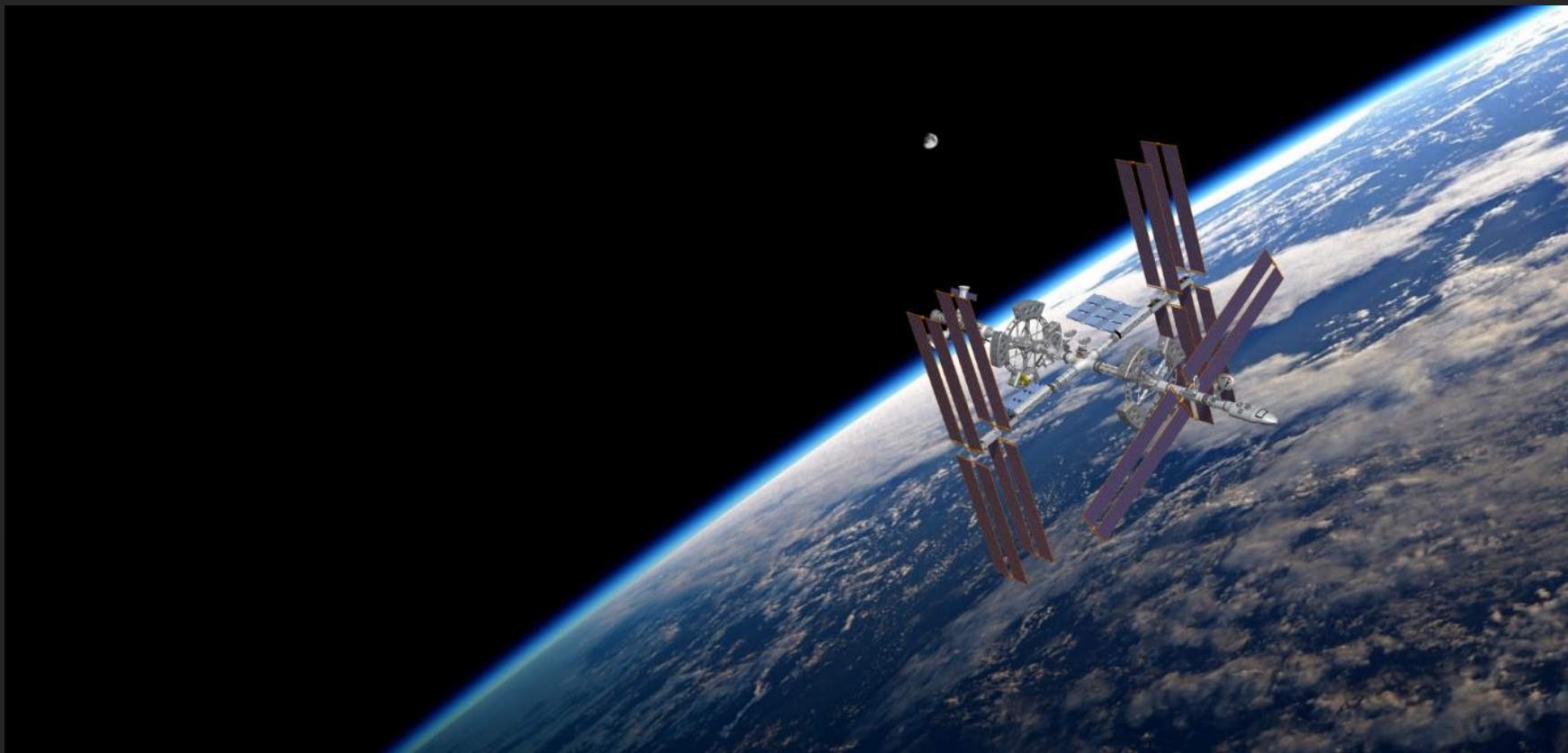

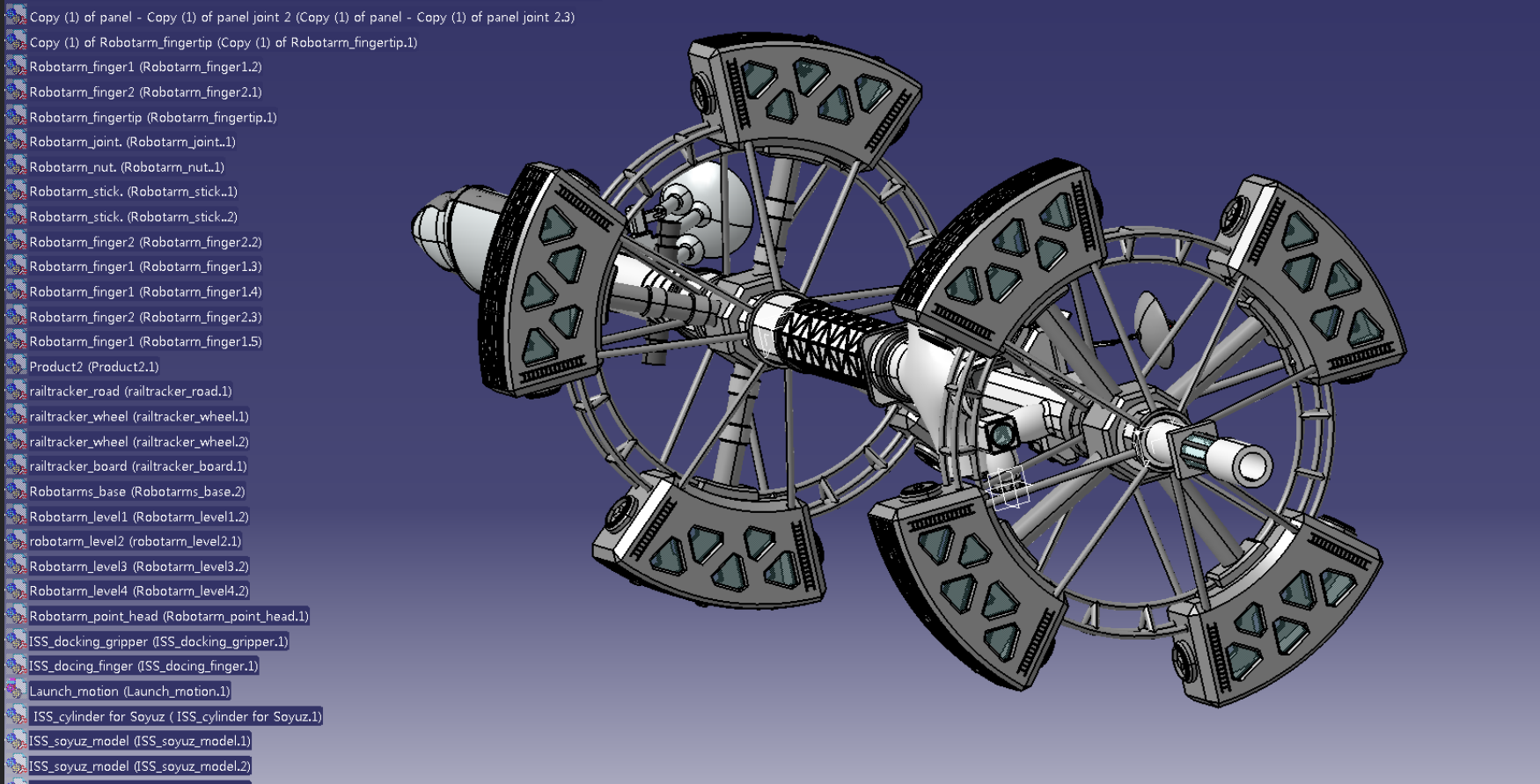

05 모델링 과정

The image shows a 3D CAD model of a complex, curved part. The model is primarily yellow and green. Several curves and supports are highlighted in red, labeled as Curve1 through Curve8 and Support1 through Support7. A blue box highlights a 'Closed Contour' on the right side of the model. To the left of the model is a feature tree with the following items: Extract.2, Extract.3, Extract.4, Extract.5, Extract.6, Extract.7, Extract.8, Extract.9, Extract.10, Extract.11, Extract.12, Extract.13, Extract.14, Extract.15, Extract.16, Extract.17, Blend.1, Blend.2, Blend.3, Blend.4, Fill.3, and Fill.4. To the right of the model is a 'Fill Surface Definition' dialog box. The dialog box has two tabs: 'Outer Boundaries' and 'Inner Boundaries'. The 'Outer Boundaries' tab is active, showing a table with 8 rows of data. The table has four columns: 'No.', 'Curves', 'Supports', and 'Continuity'. The 'Continuity' column is set to 'Tangent' for all rows. Below the table are buttons for 'AddAfter', 'Replace', 'Remove', 'AddBefore', 'ReplaceSupport', and 'RemoveSupport'. The 'Continuity' dropdown is set to 'Tangent'. Below the dropdown is a 'Passing element(s):' field with 'No selection' and a search icon. There are checkboxes for 'Planar Boundary Only' and 'Deviation: 0.001mm'. There is also a checked checkbox for 'Canonical portion detection'. At the bottom of the dialog box are 'OK', 'Cancel', and 'Preview' buttons.

No.	Curves	Supports	Continuity
1	Extract.14#Edge.25	Extract.14	Tangent
2	Blend.1#Edge.26	Blend.1	Tangent
3	Extract.2#Edge.27	Extract.2	Tangent
4	Blend.2#Edge.28	Blend.2	Tangent
5	Extract.6#Edge.29	Extract.6	Tangent
6	Blend.3#Edge.30	Blend.3	Tangent
7	Extract.10#Edge.31	Extract.10	Tangent
8	Blend.4#Edge.32	Blend.4	Tangent

05 모델링 과정

The image displays a CAD software interface with a 3D model of a curved surface and a 'Multi-Sections Surface Definition' dialog box.

3D Model: A yellow, curved surface is shown with several black lines representing sections and guides. Labels include 'Support1', 'Closing Point1', 'Closing Point2', 'Closing Point3', 'Closing Point4', 'Section1', 'Section2', 'Section3', 'Section4', 'Guide1', 'Guide2', and 'Guide3'.

Multi-Sections Surface Definition Dialog:

No.	Section	Supports	Continuity	Closing Point
1	Join.5#Edge.5	Join.5	Tangent	Split.3#Vertex.13
2	Join.1			Point.5
3	Join.2			Point.6
4	Join.3			Point.7

No.	Guide	Supports	Continuity
1	Split.3		
2	Split.4		

Buttons: Replace, Remove, Add

Continuity: Tangent

Smooth parameters:

- Angular correction: 0.5deg
- Deviation: 0.001mm

Buttons: OK, Cancel, Preview

Left Panel (Feature Tree):

- Intersect.7
- Intersect.8
- Intersect.9
- Sketch.34
- Sketch.35
- Sketch.36
- Point.3
- Point.4
- Sketch.37
- Sketch.38
- Sketch.39
- Join.1
- Join.2
- Join.3
- 'Merging distance'
- Split.3
- Split.4
- Join.5
- Extremum.4
- Extremum.5
- Extremum.6
- Multi-sections Surface.4
- Join.6
- Split.5
- Split.6

05 모델링 과정

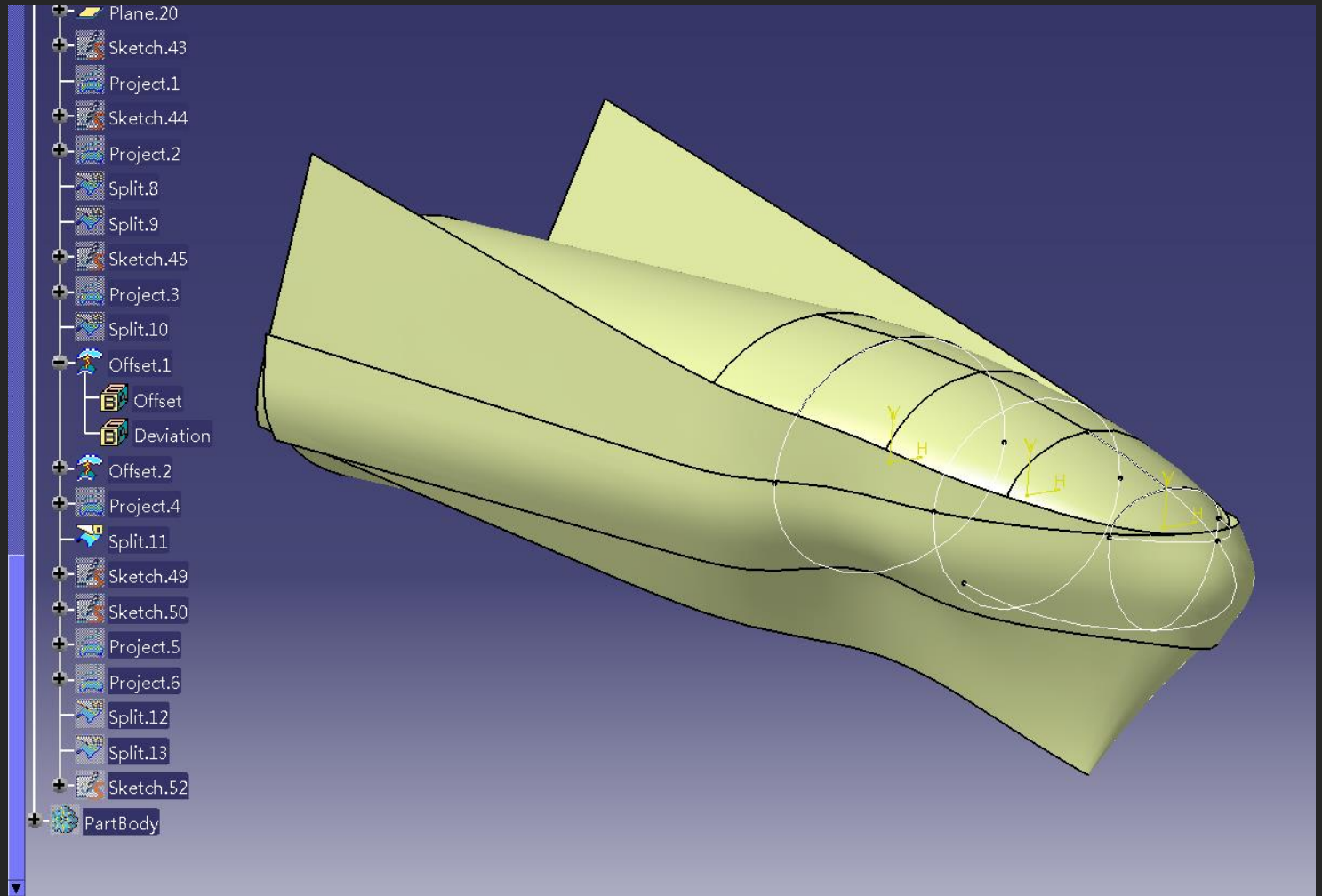

05 모델링 과정

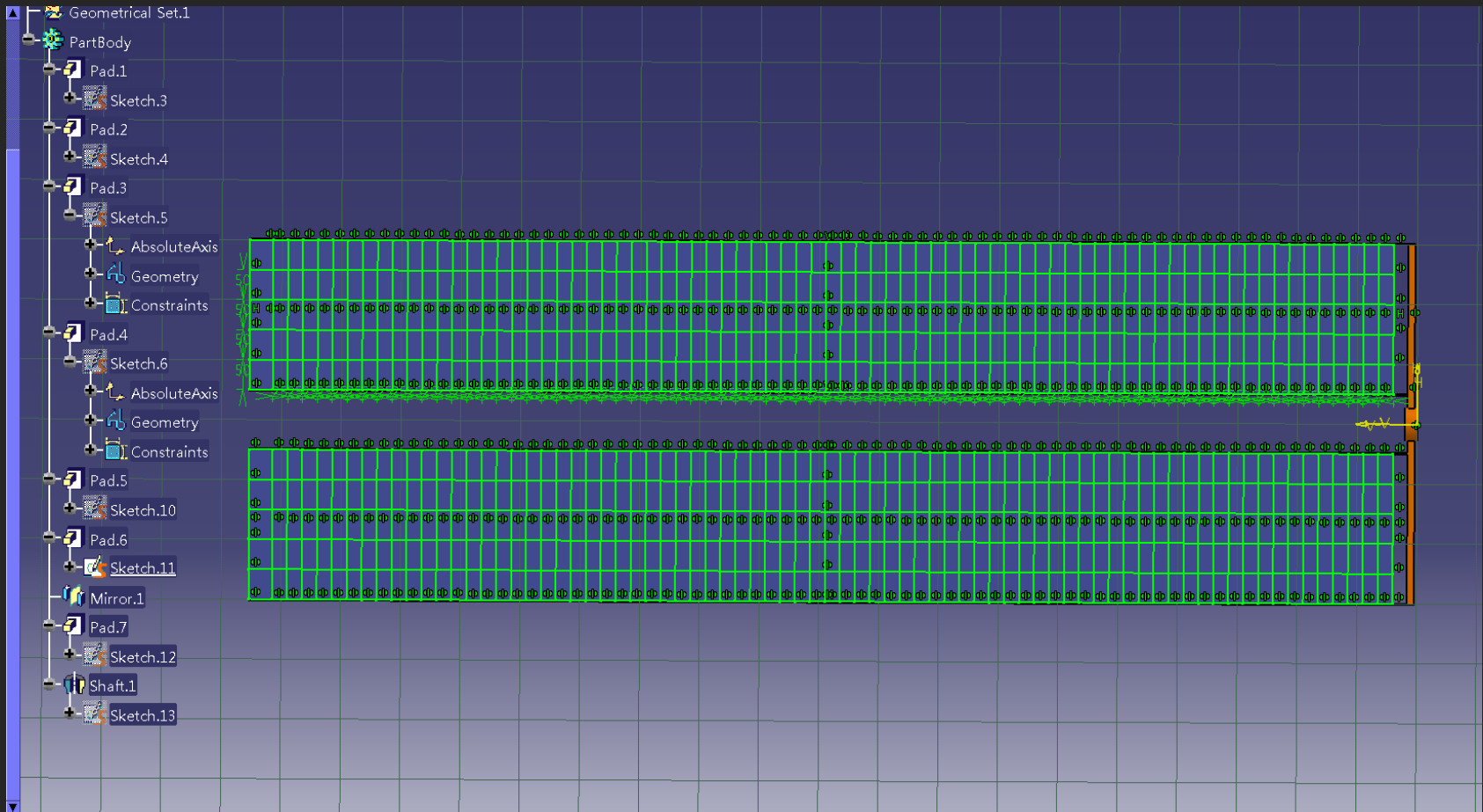

05 모델링 과정

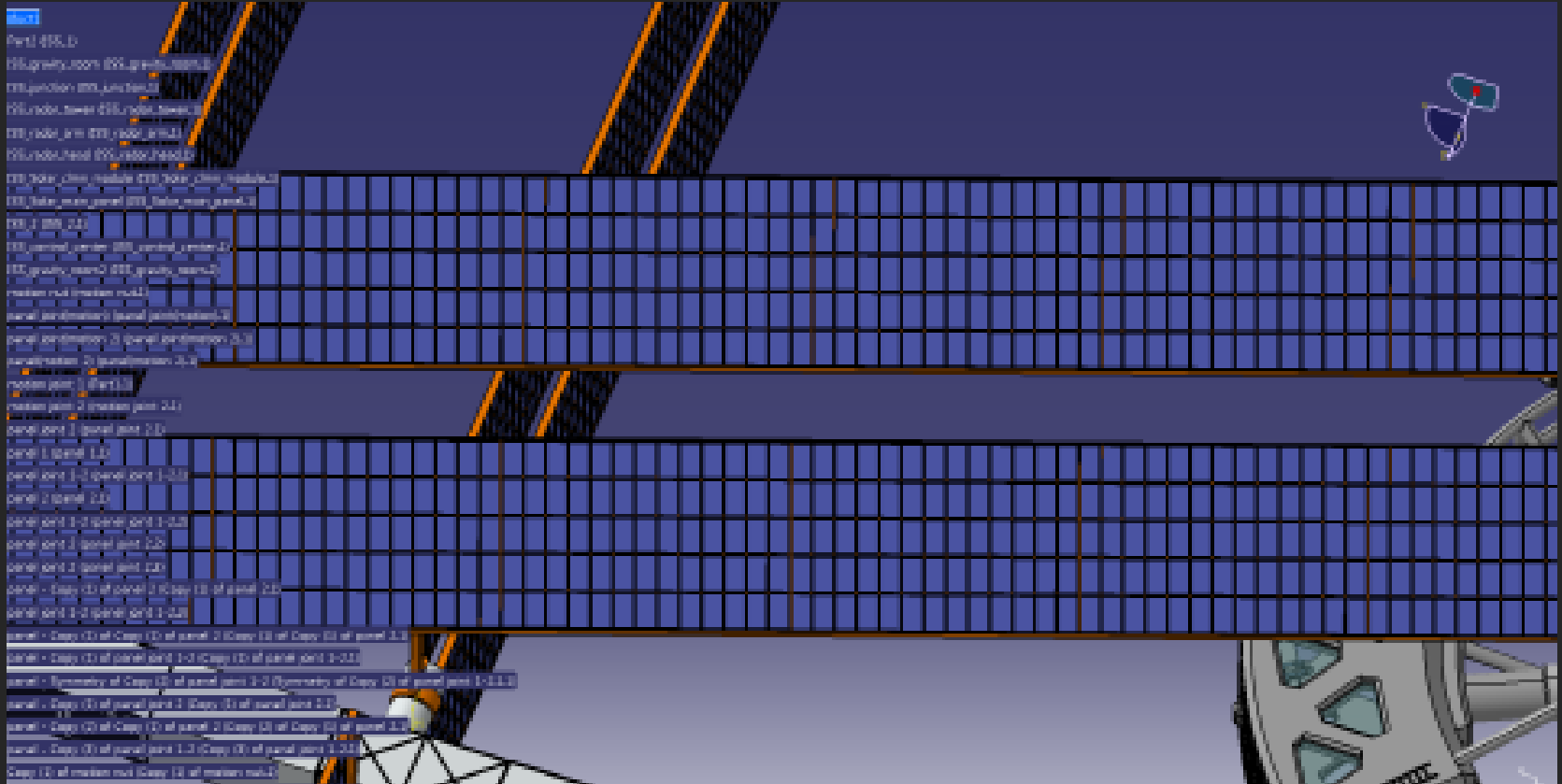

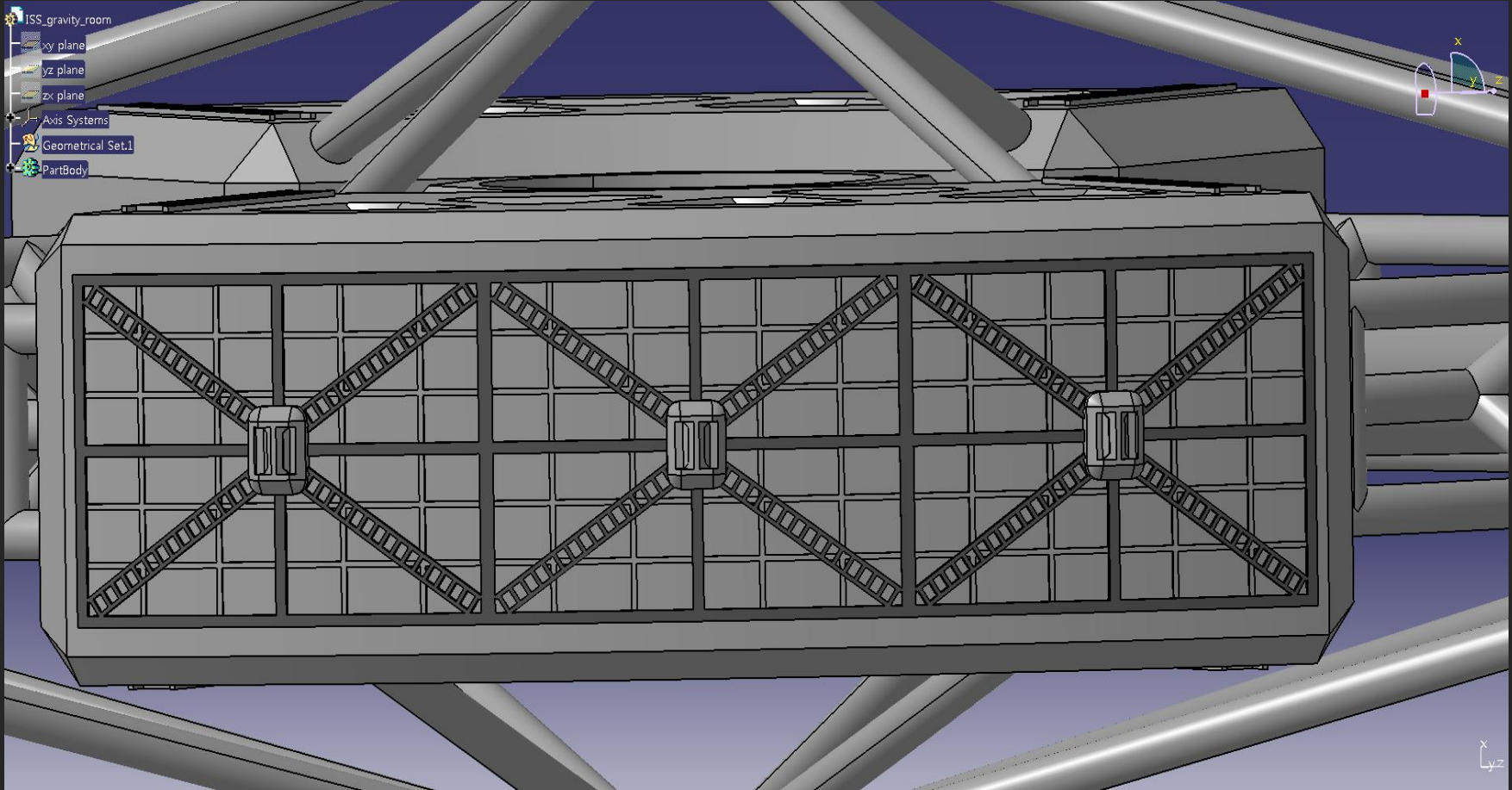

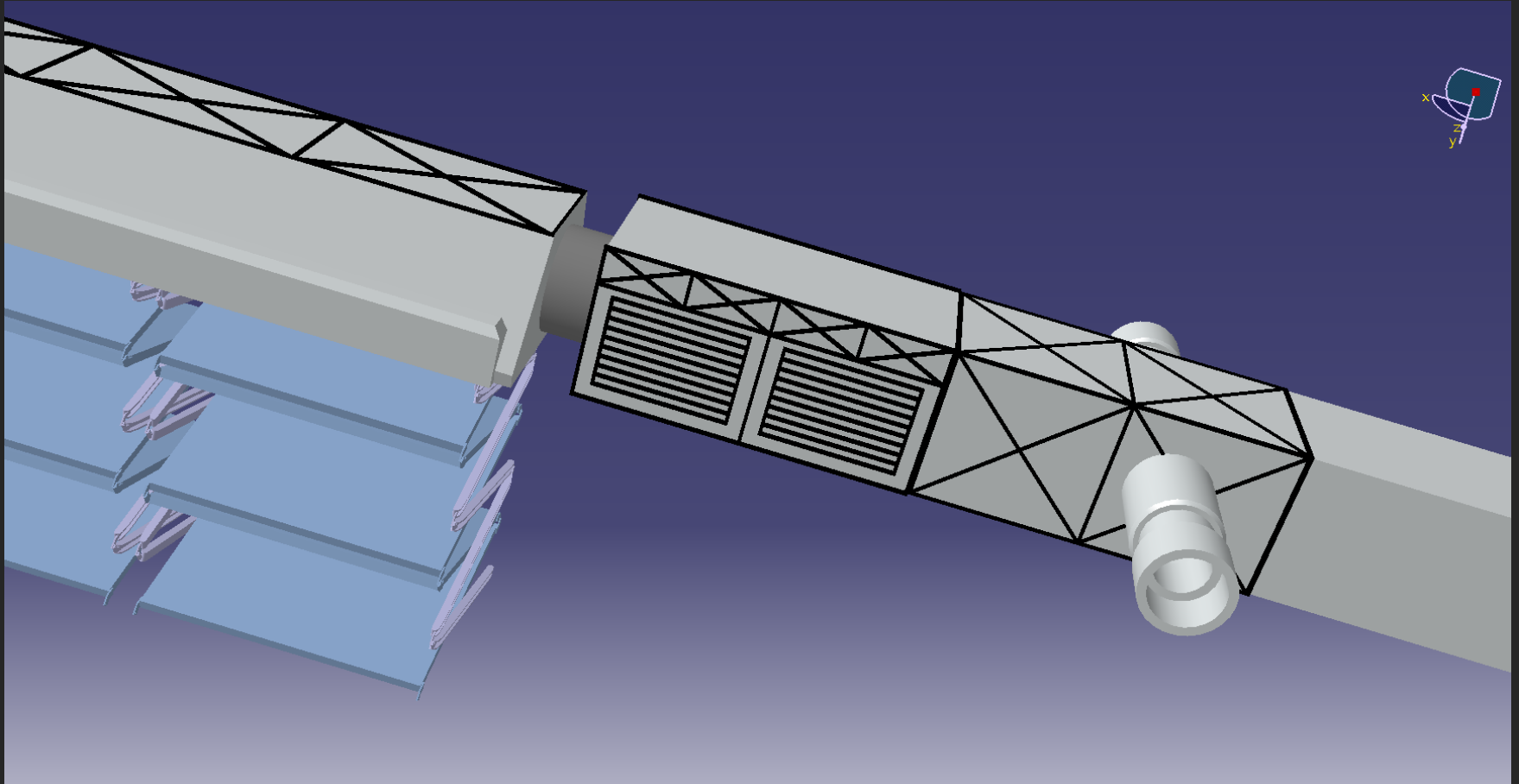



Module
디자인

05 모델링 과정

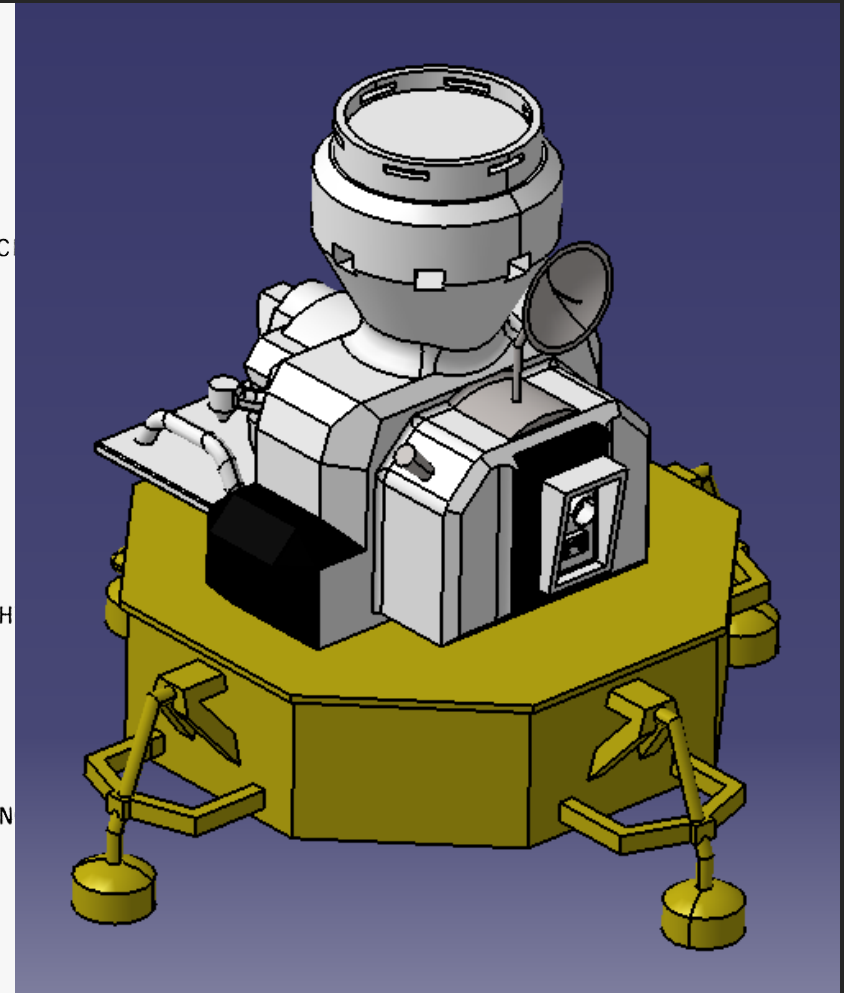
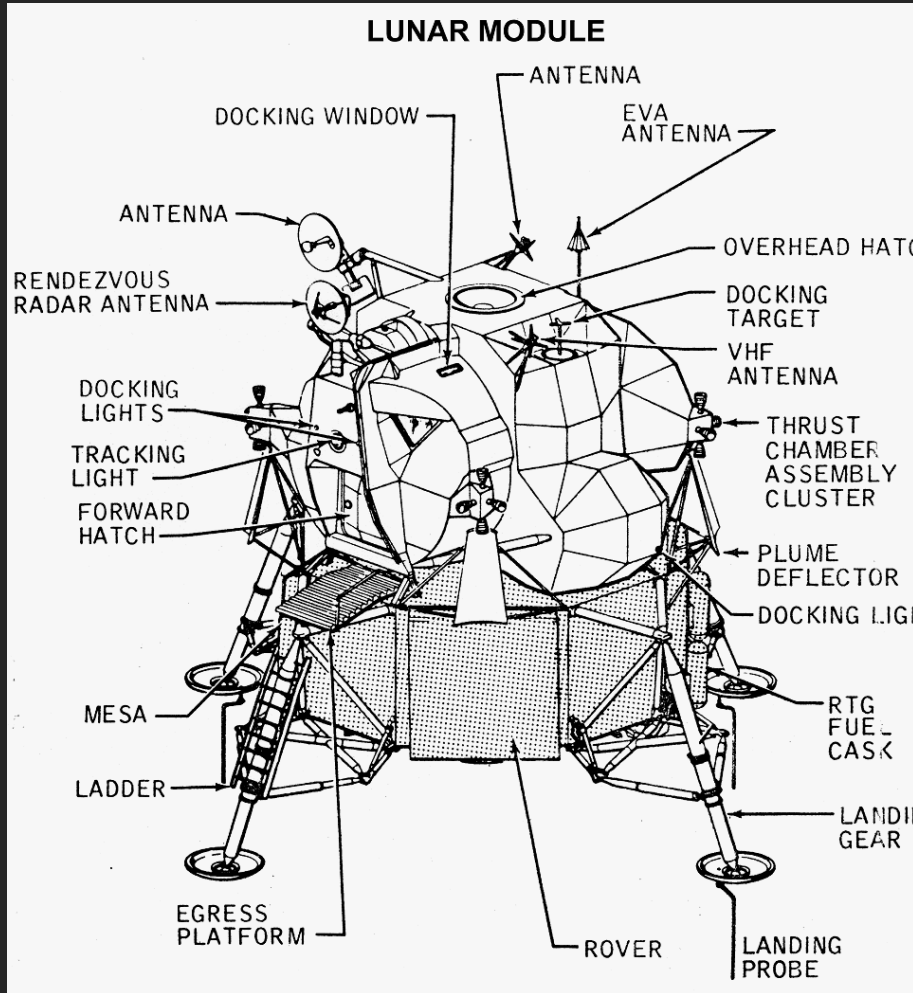

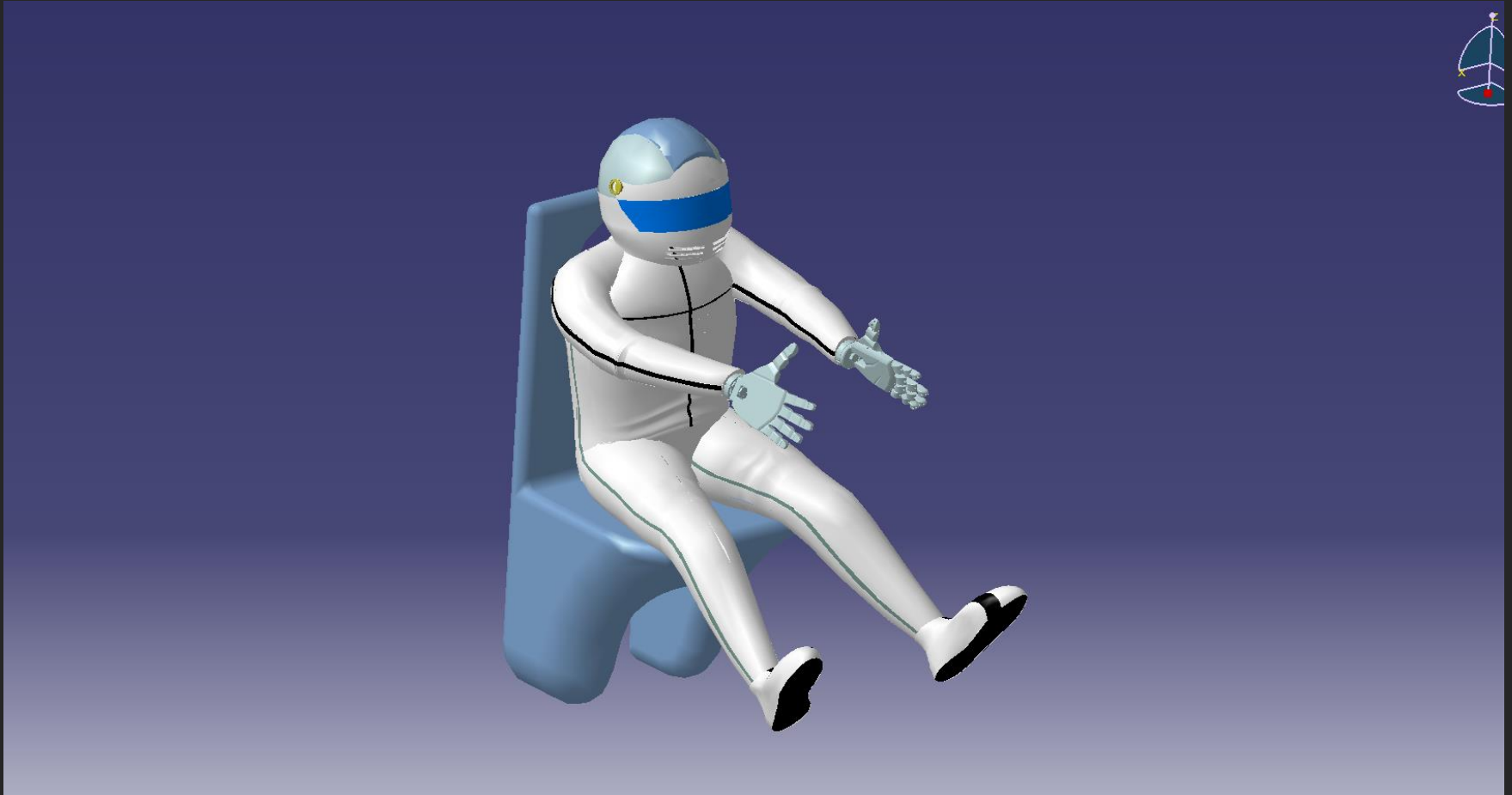

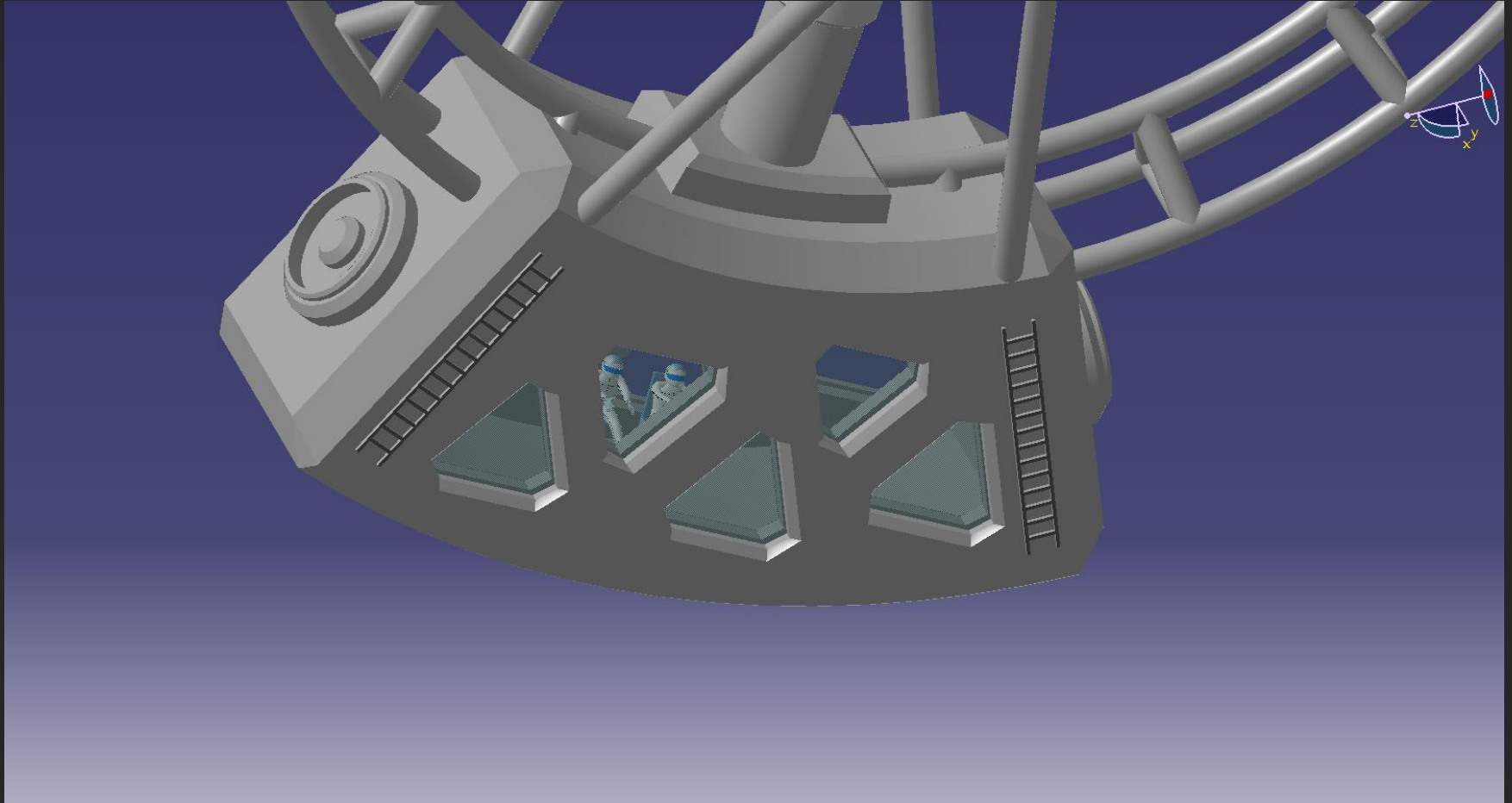



Kinematic
디자인

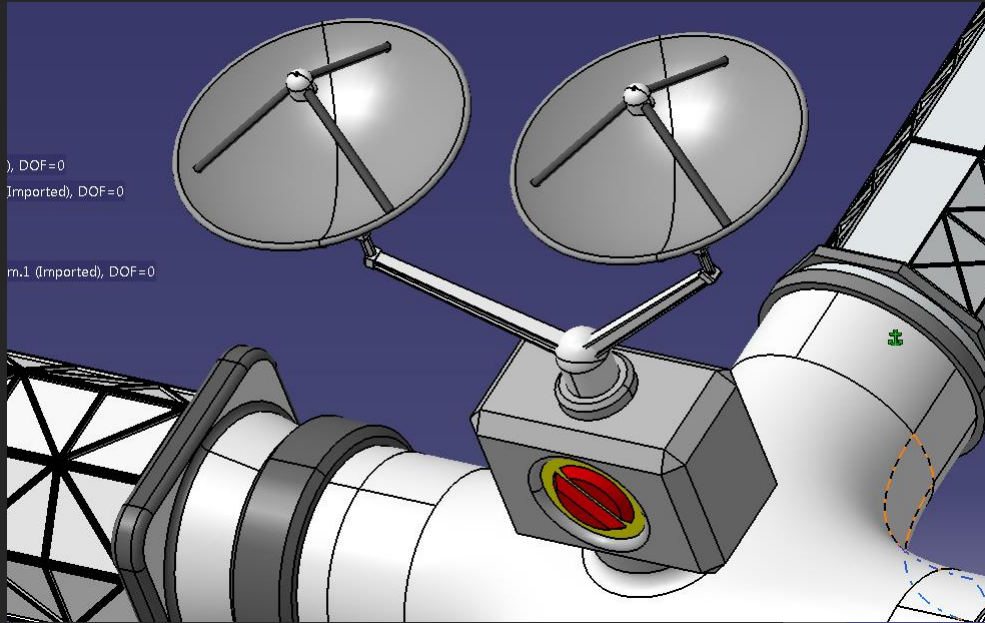

DOF = 3

Radar

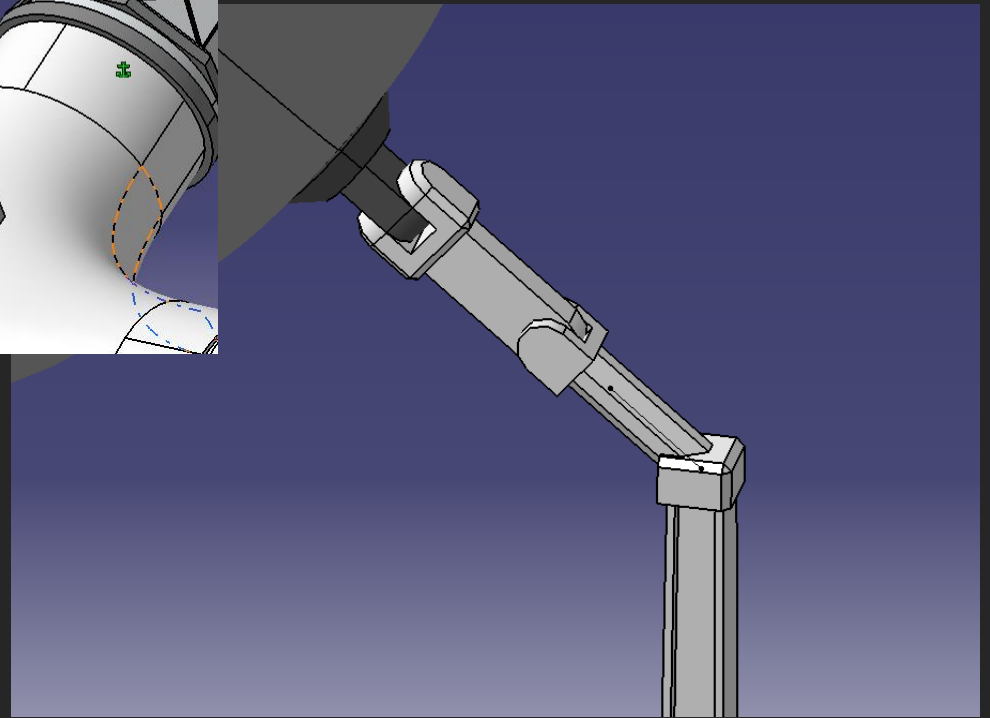

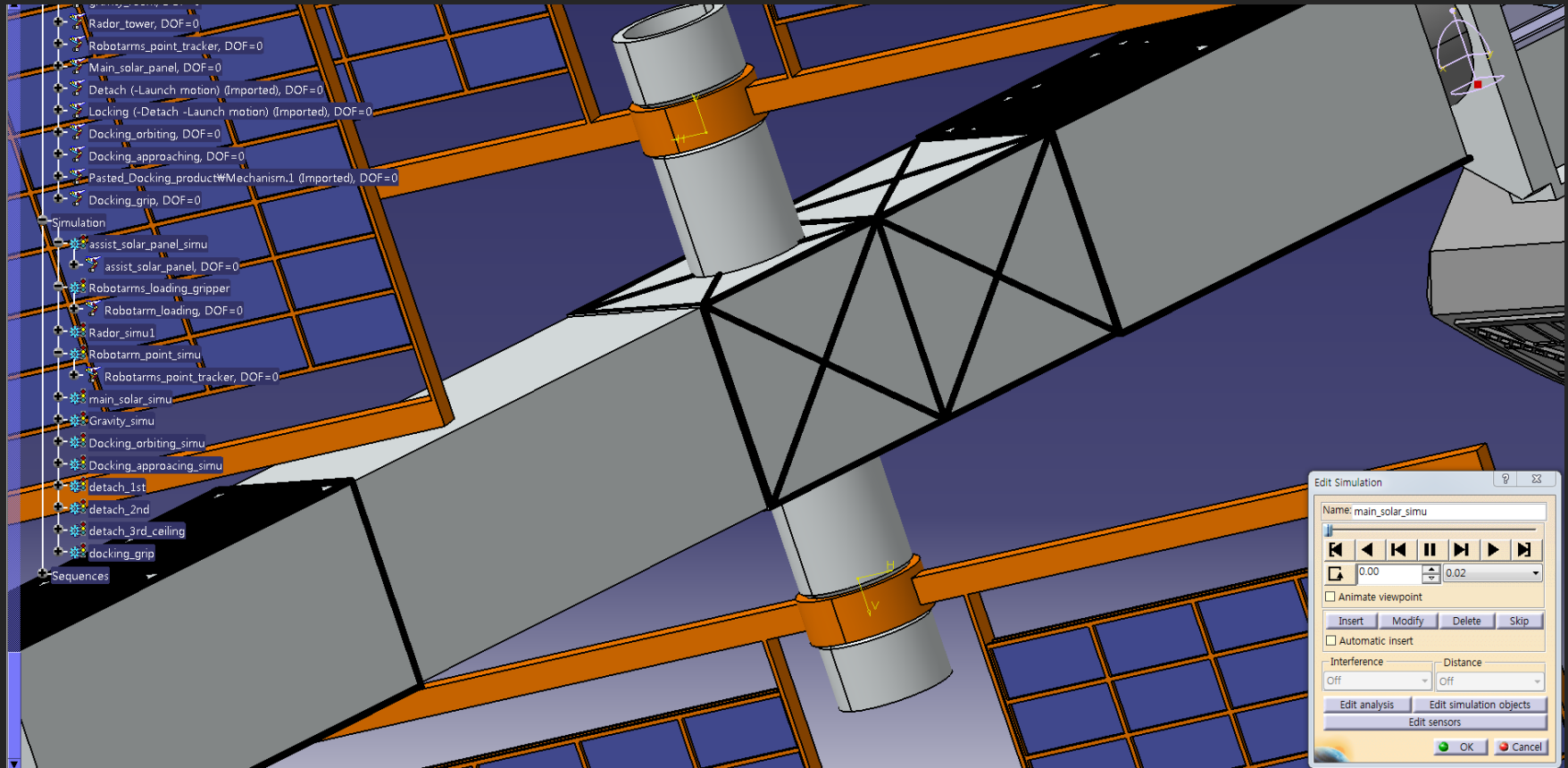

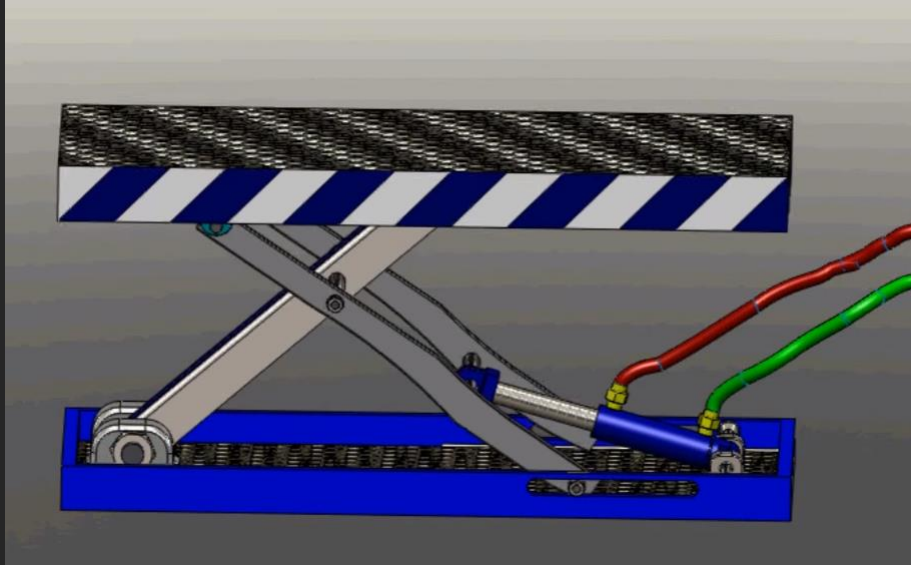

Solar Panels

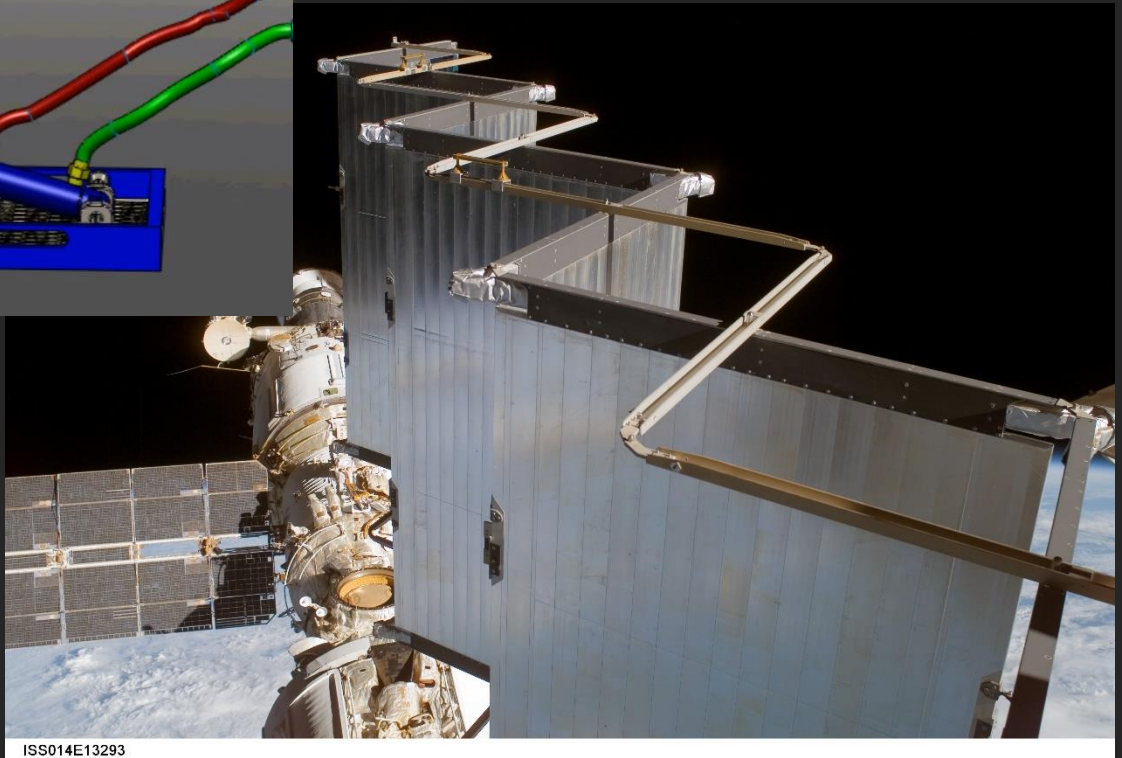

05 모델링 과정

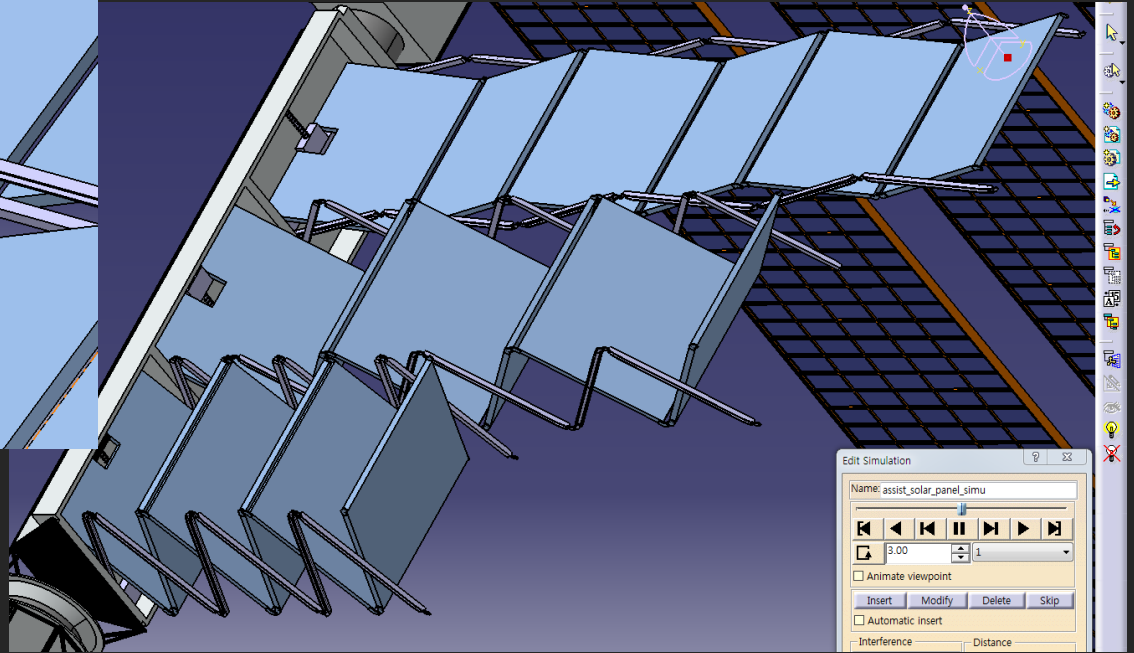
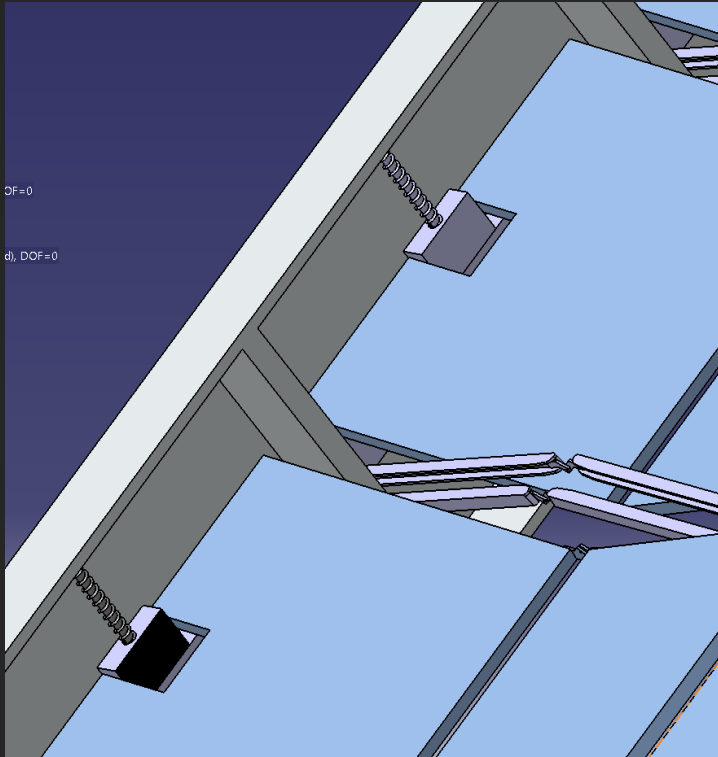



Robotic Arm

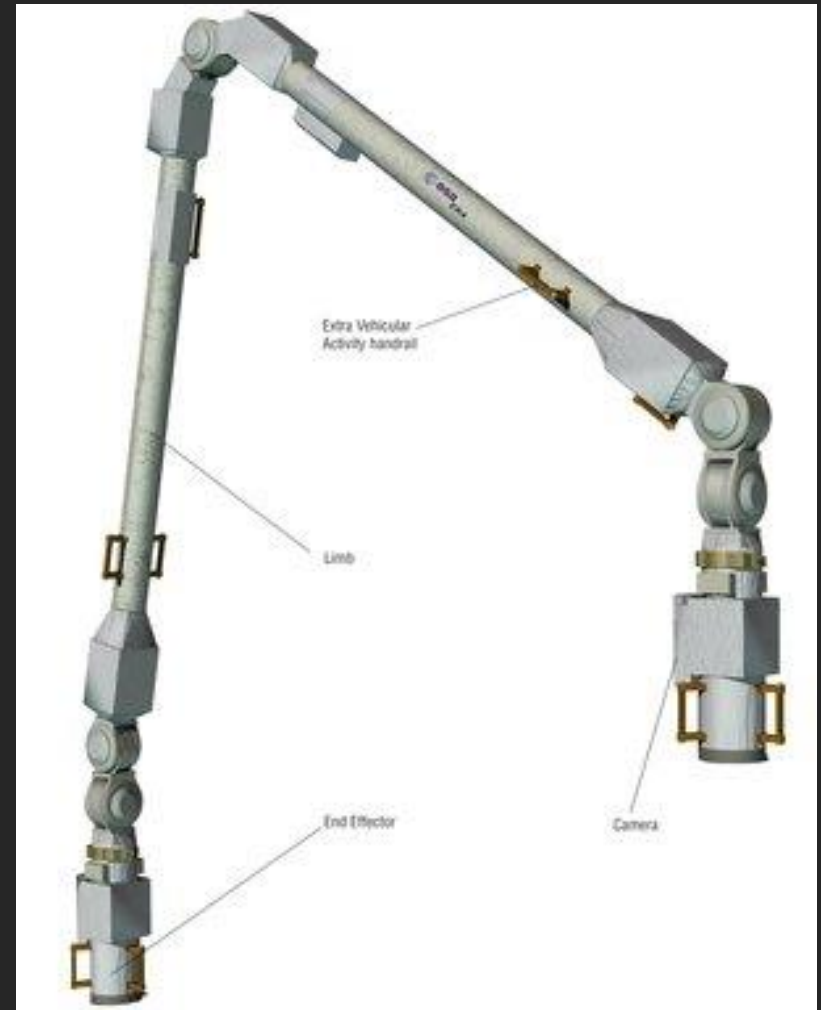



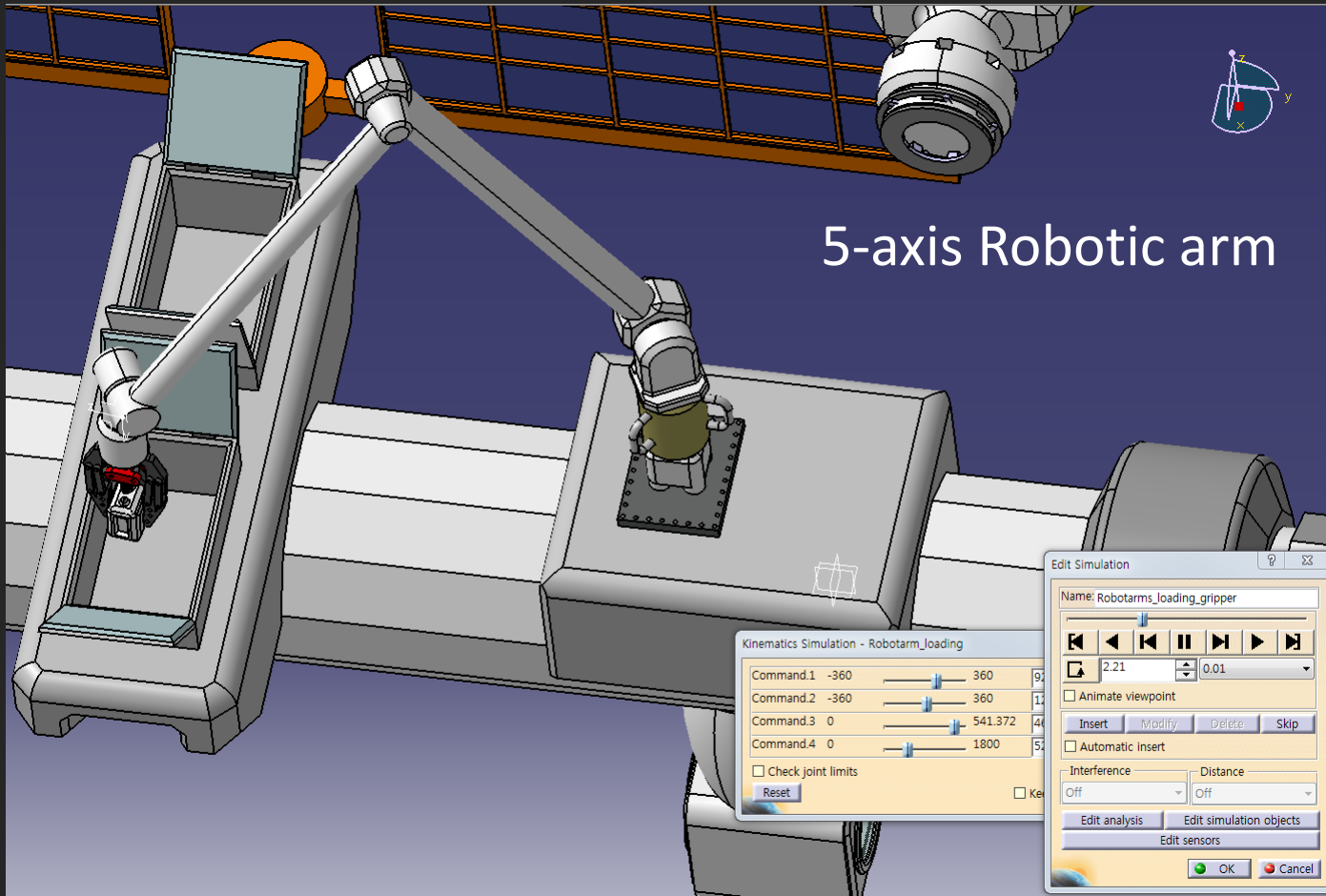

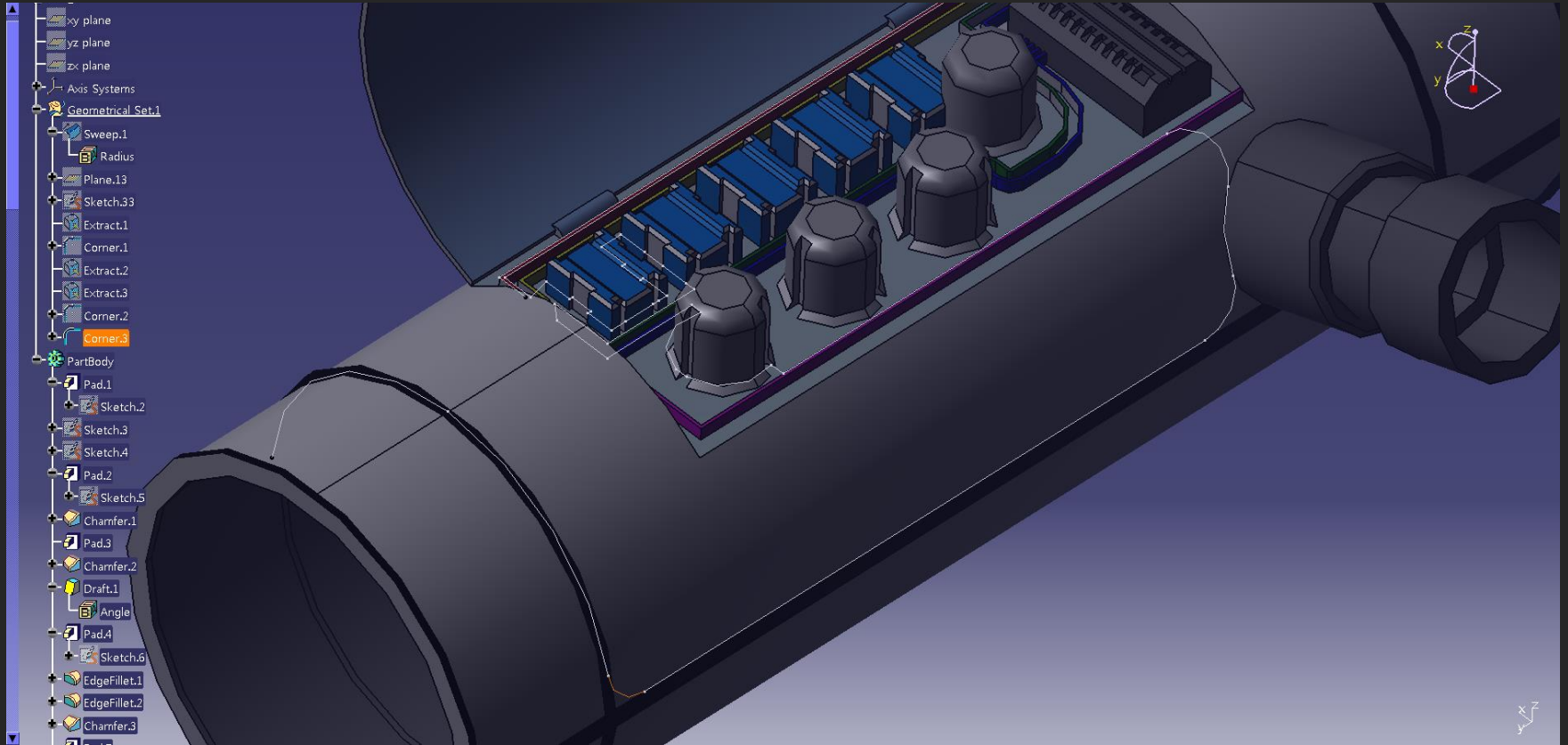

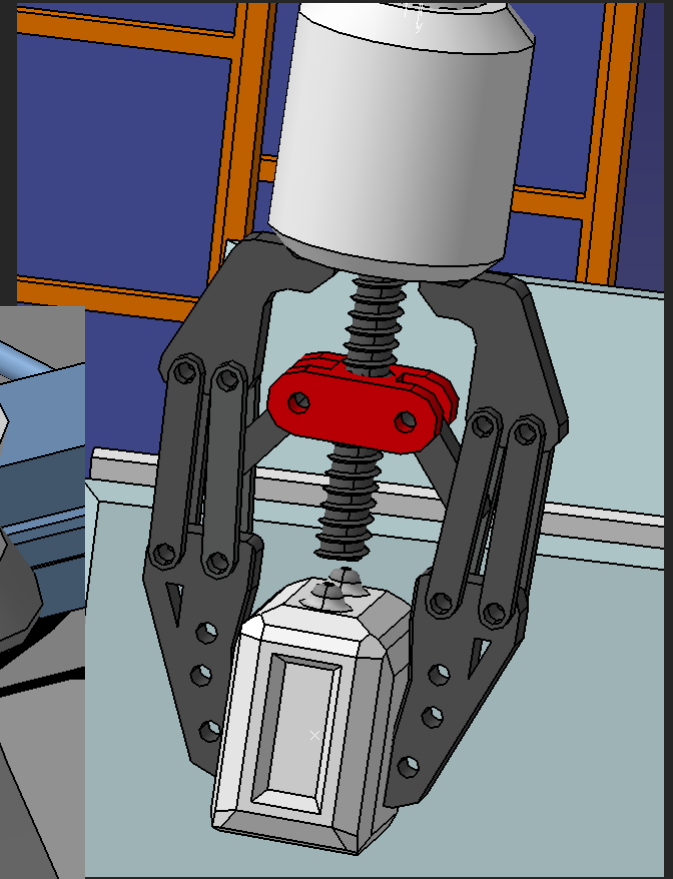
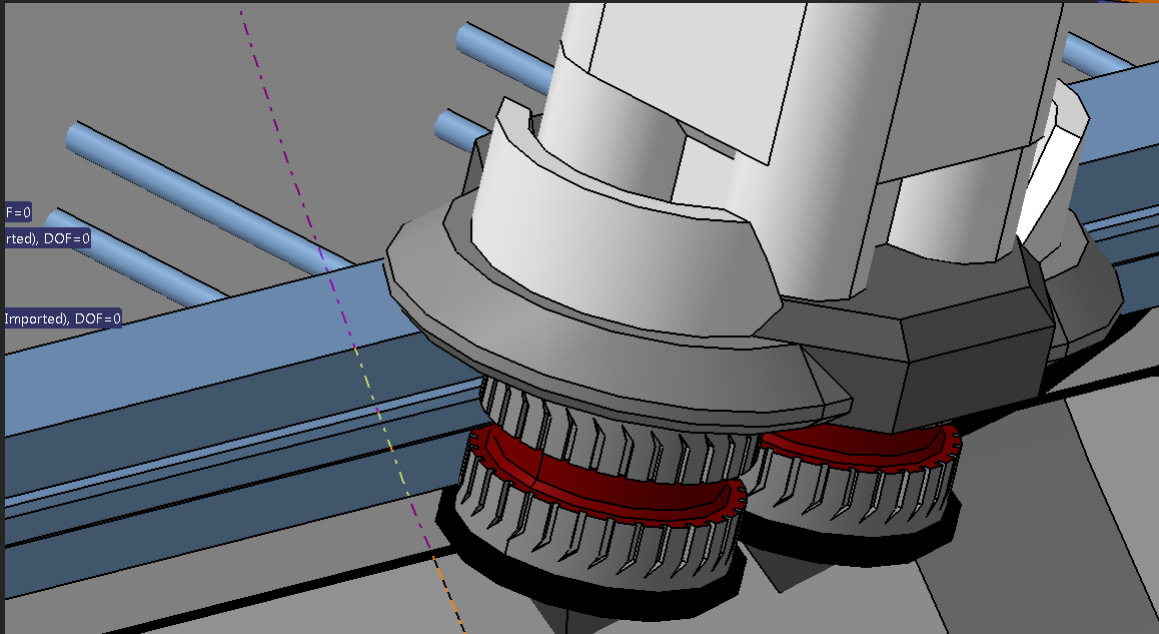

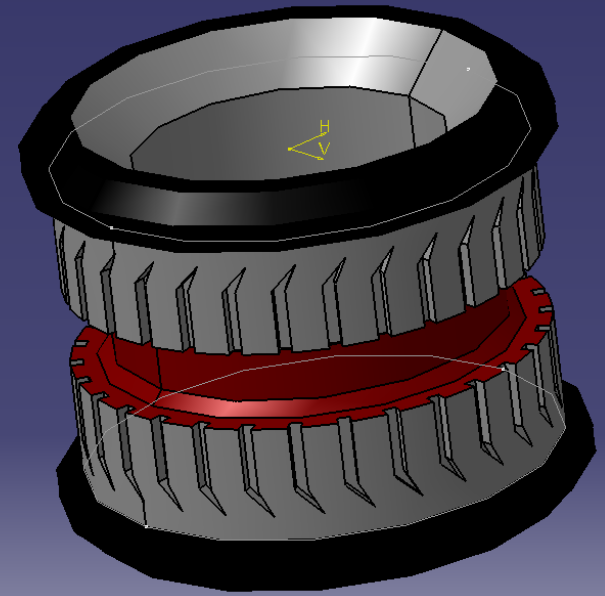
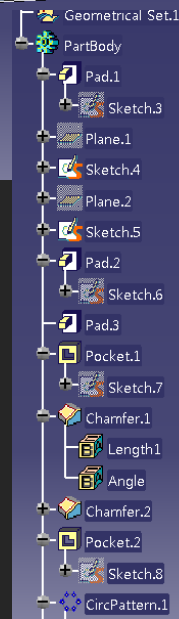
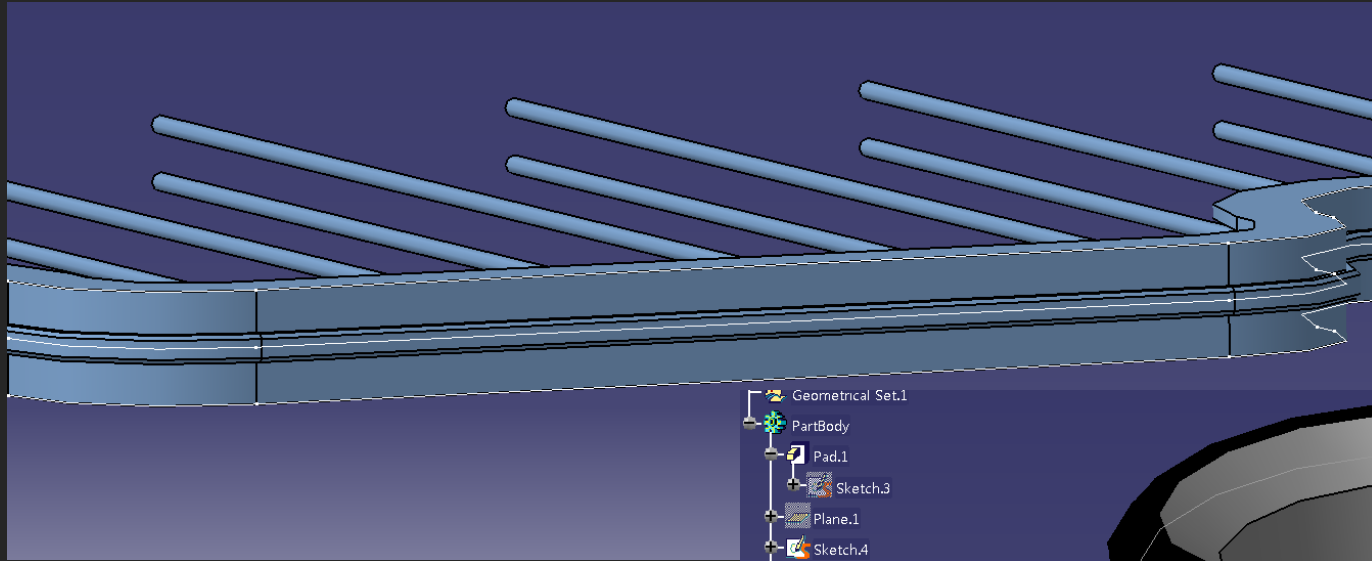

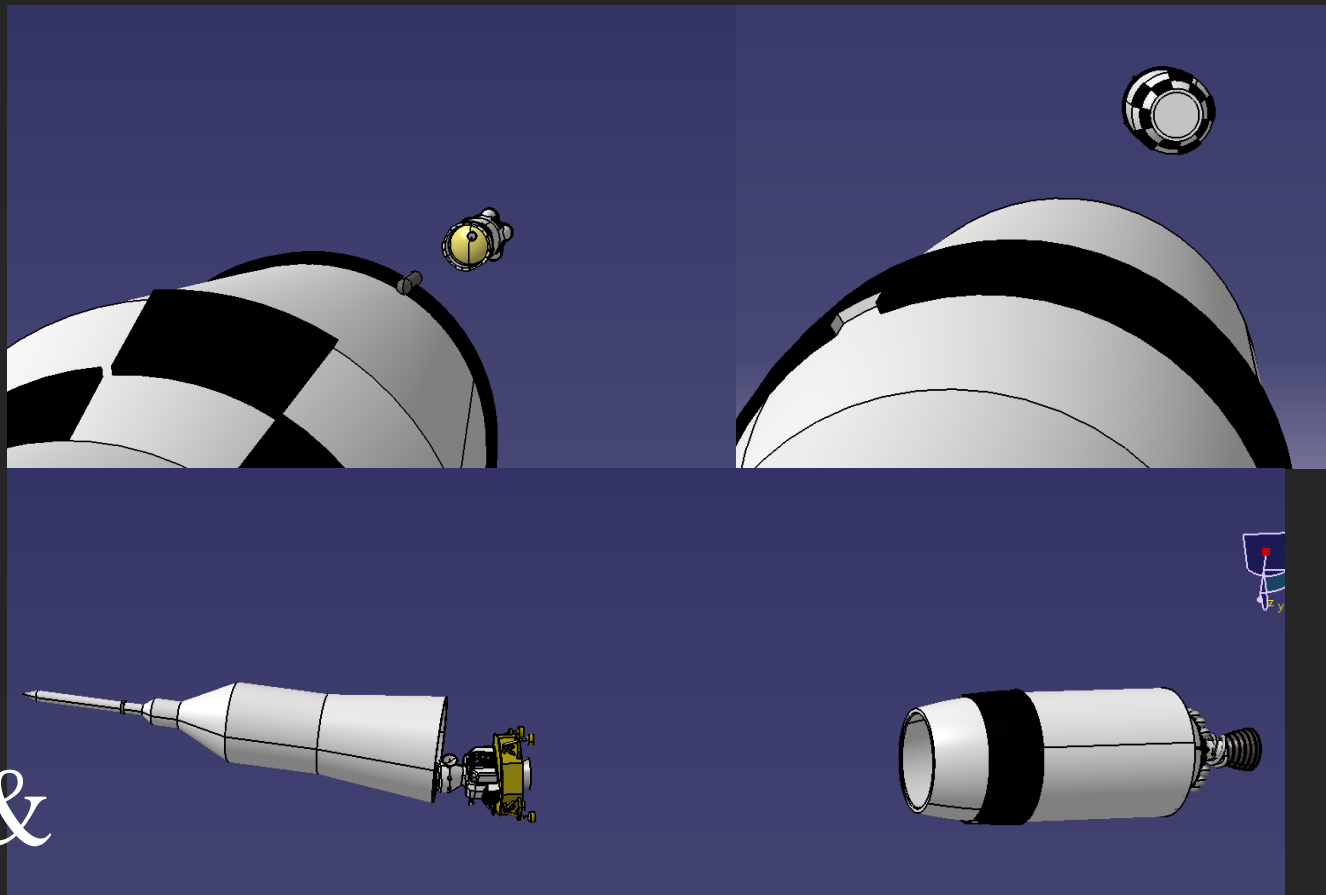

Detach &
Docking

Motion Unit

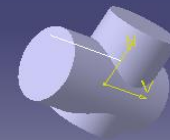
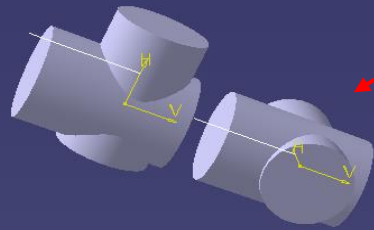

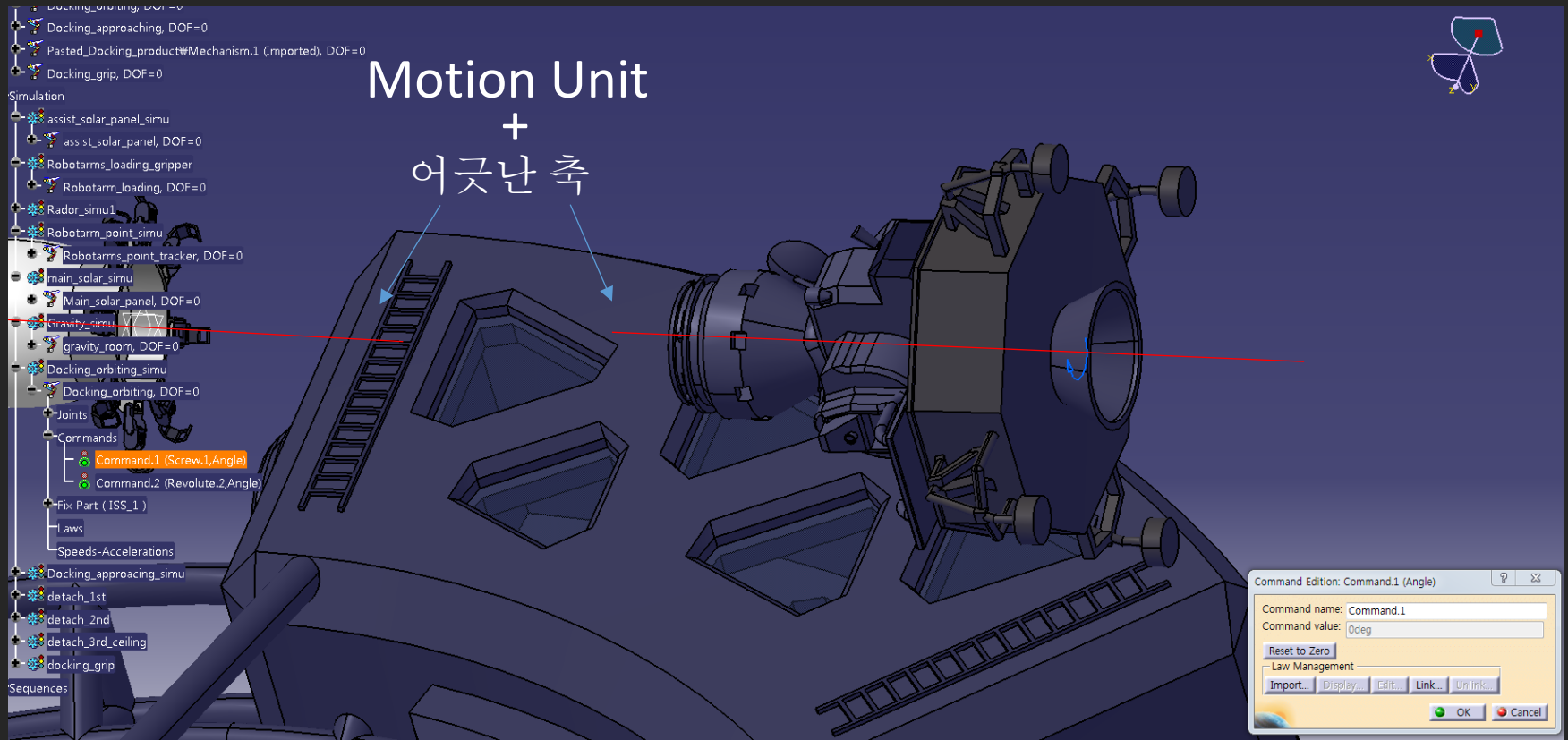

05 모델링 과정

일시 정지

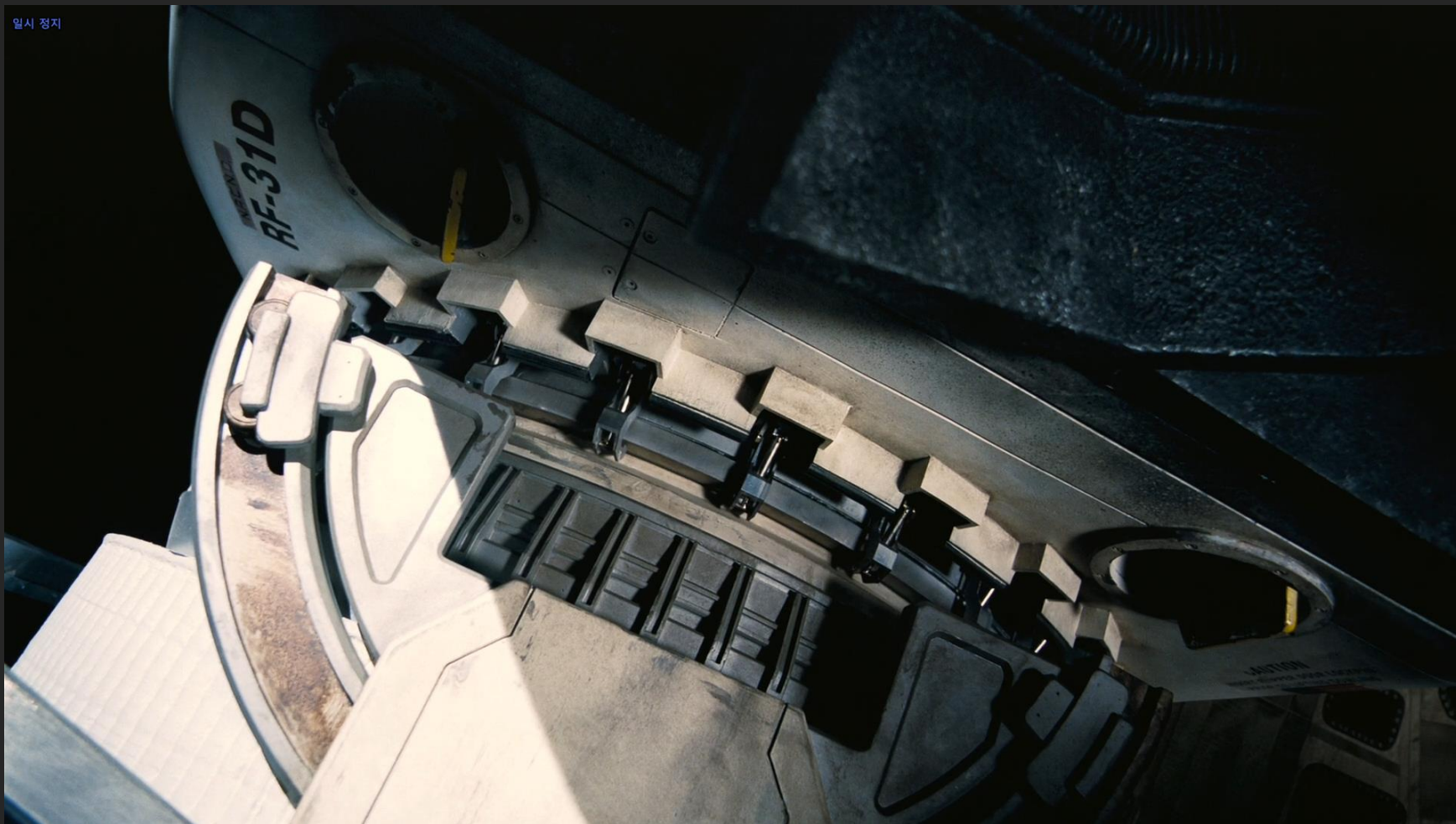

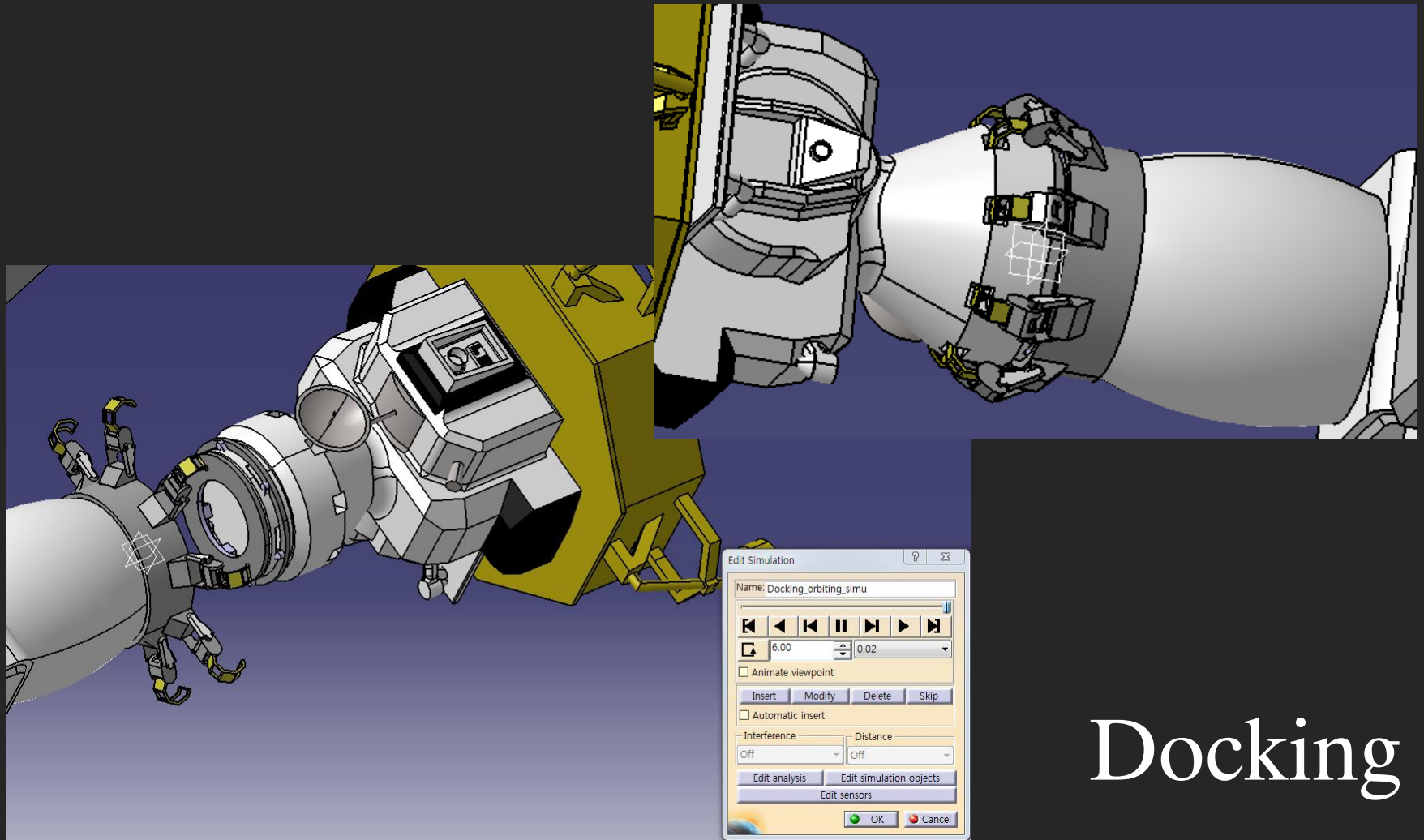

Docking

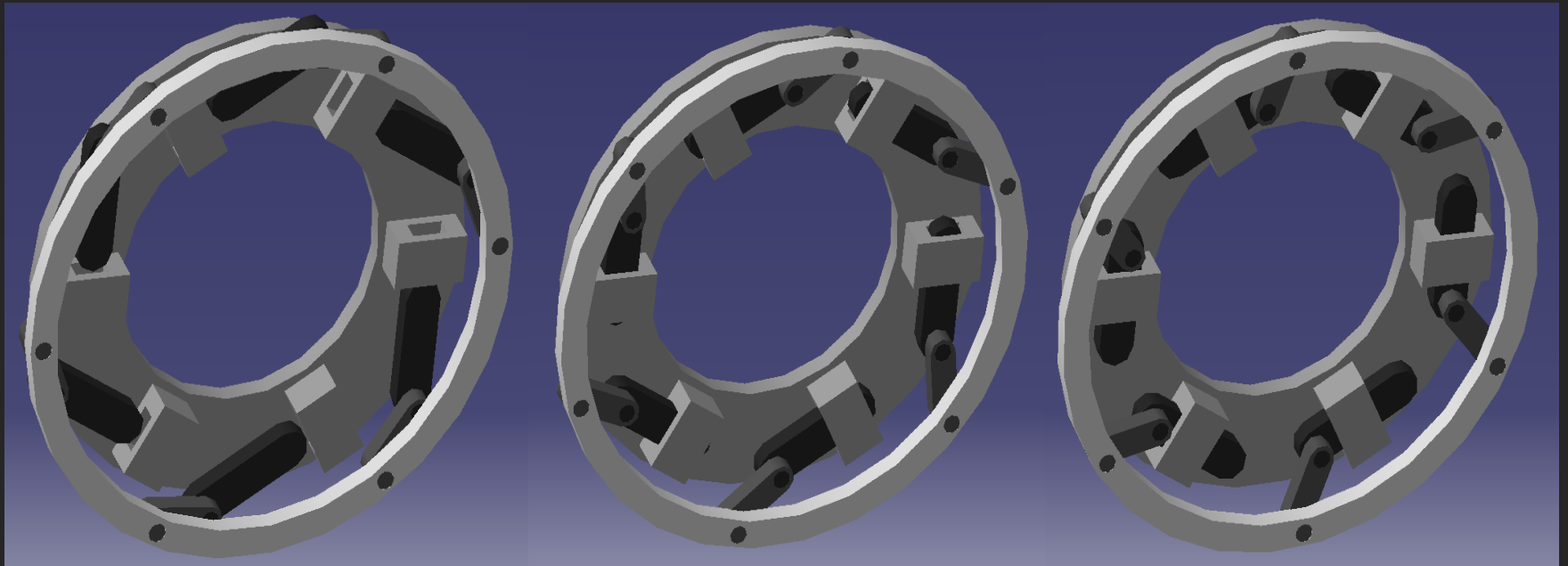

Locking



6

Camera

Stephen Docking

06 Camera

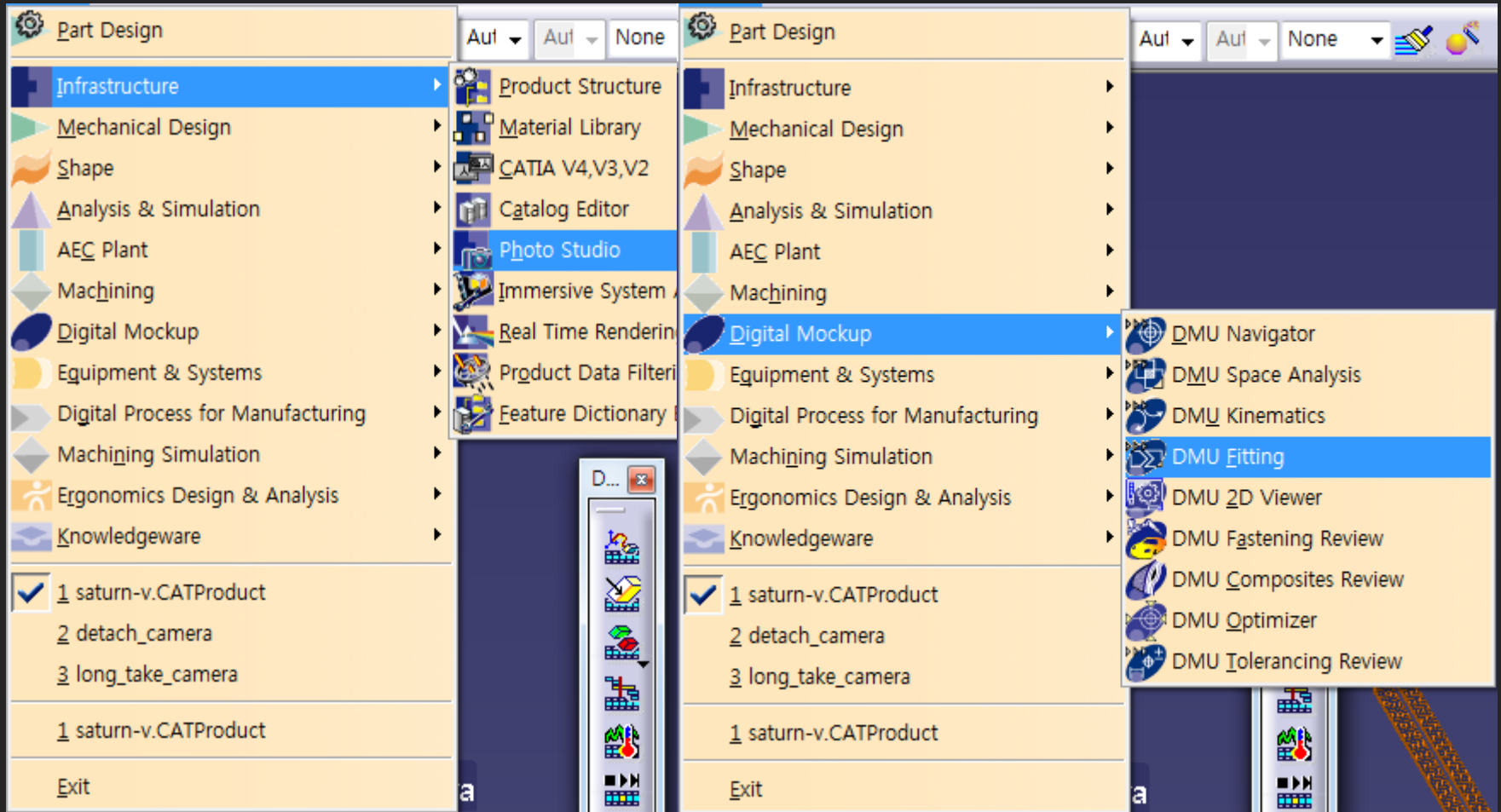

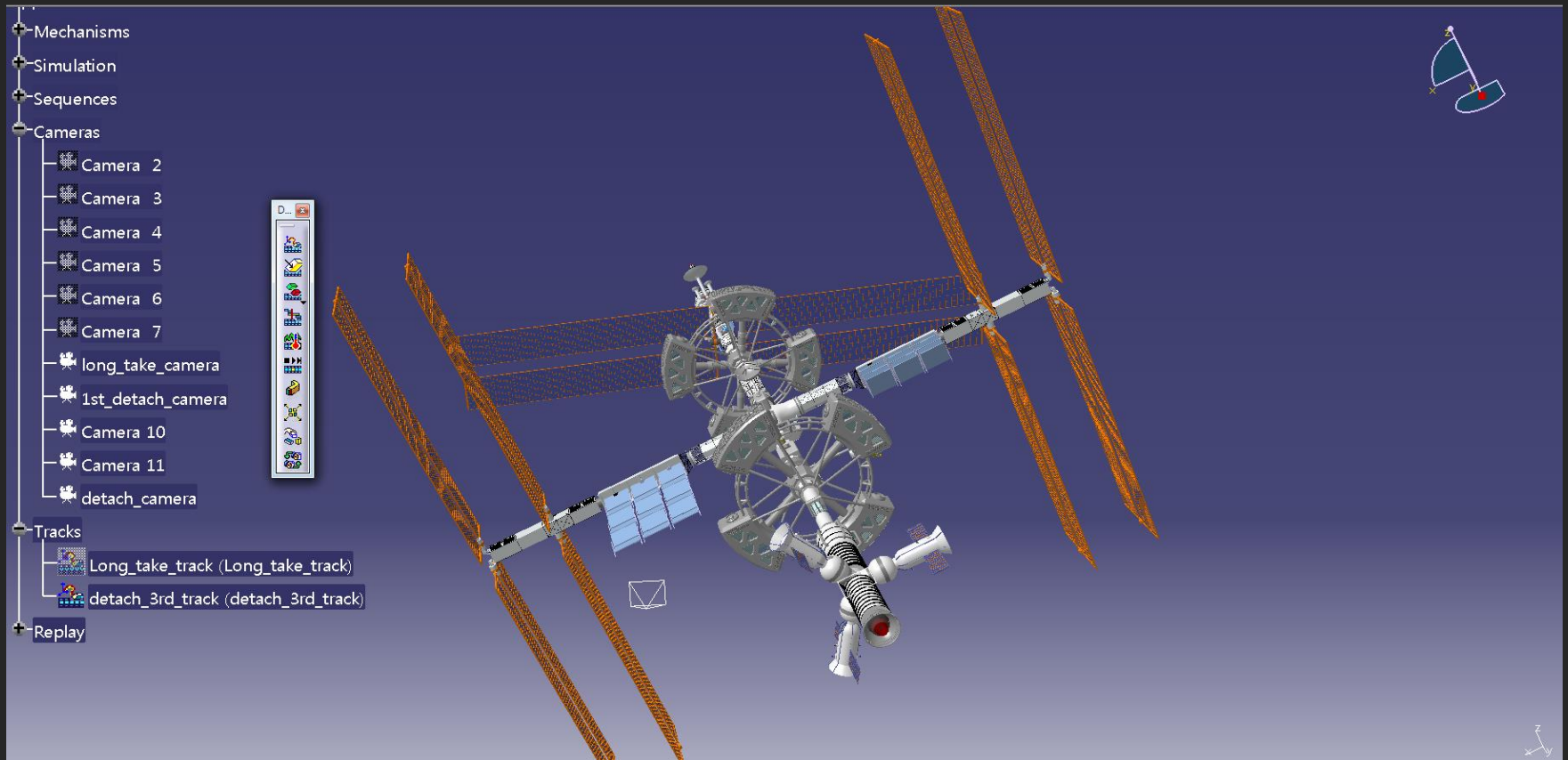

06 Camera

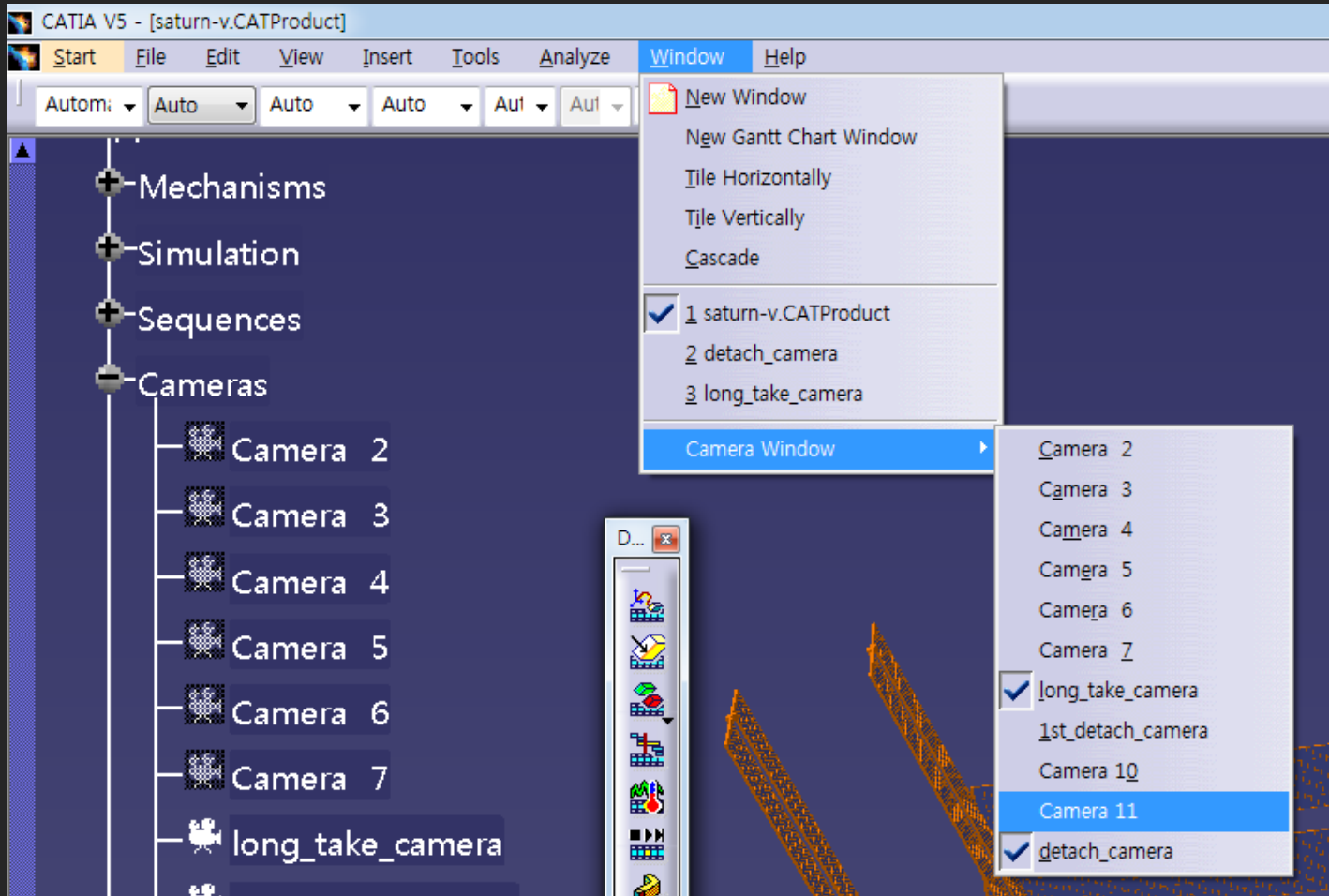

06 Camera

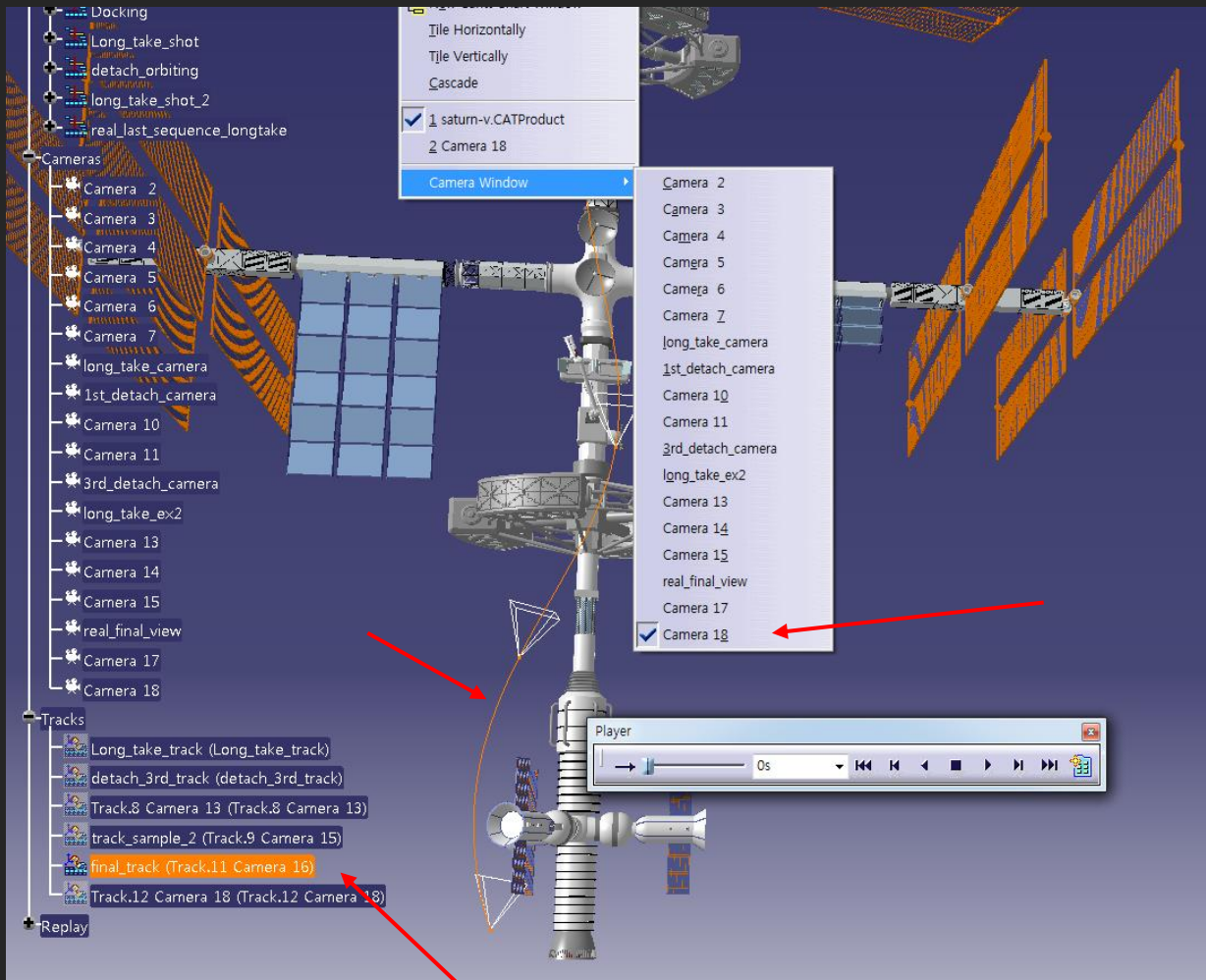



7

아쉬운 점

Stephen Docking



8

Q & A

Stephen Docking