



CAD Team Project

Team FPS

2011012131 강한별

2011012197 김동선

2011012346 신현기



INDEX.

1

Team name

2

Motive
& Subject

3

Modeling

4

Kinematics

1 Team name

FPS : First person shooting, 1인칭 슈팅 게임

F

for

P

perfect

S

&

special

2. Motive & Subject

Submachine Gun



2. Motive & Subject

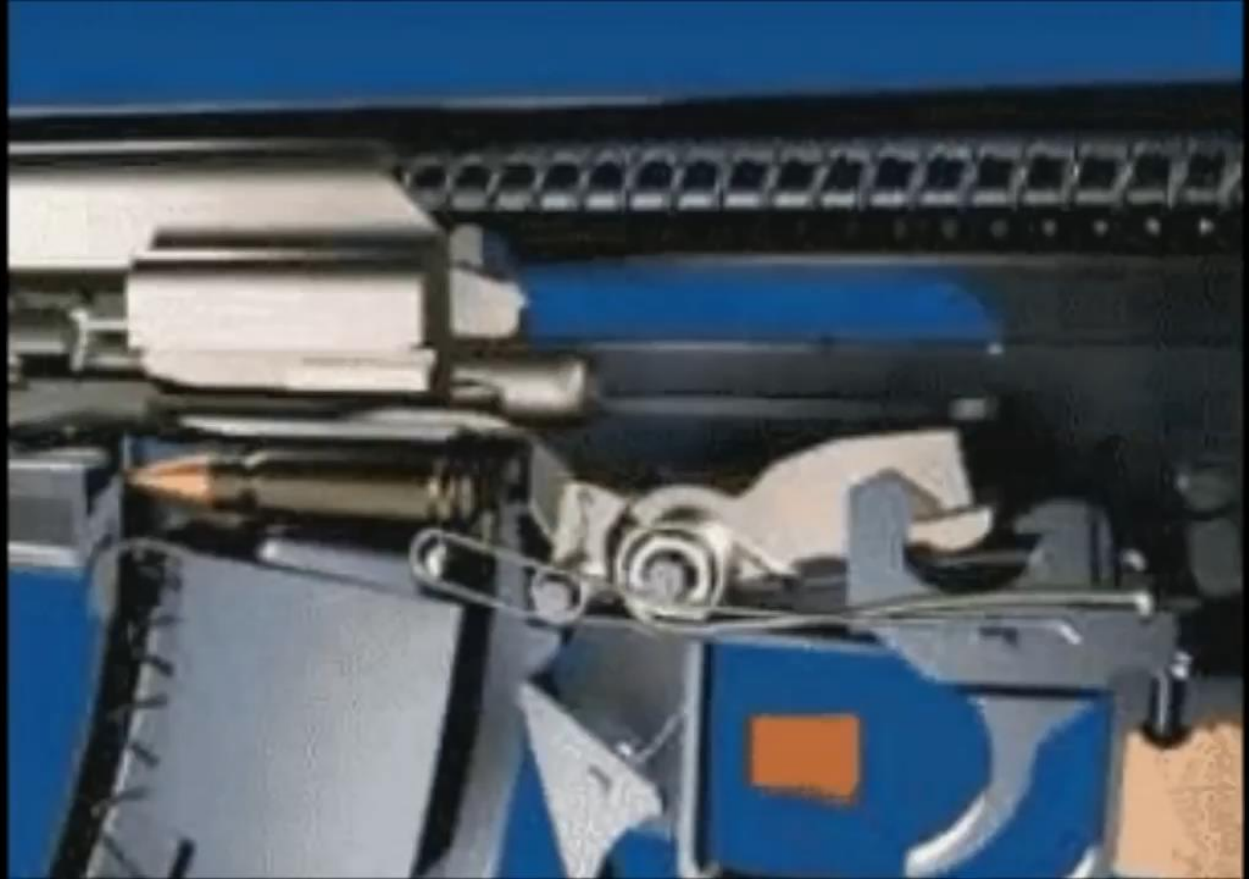

2. Motive & Subject





3. Modeling

3. Modeling

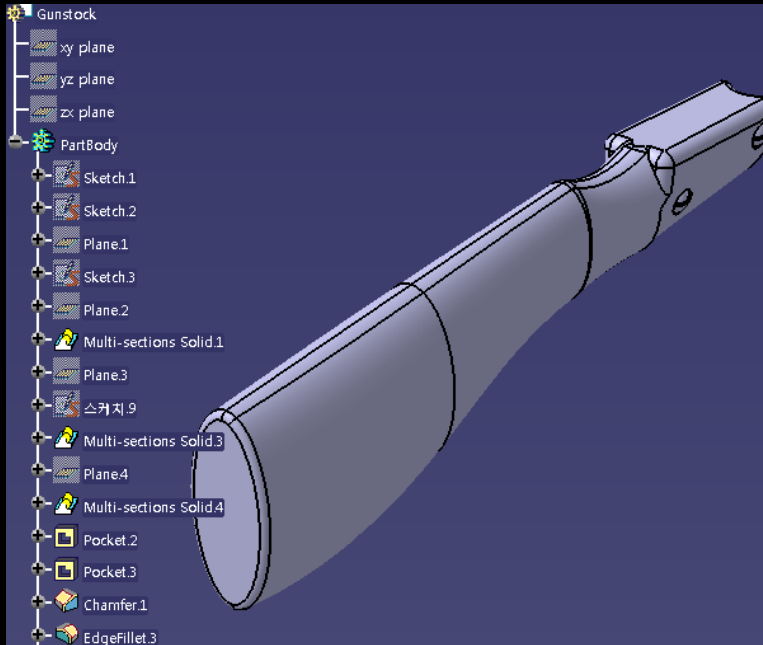

Part : 개머리판

Function

: Multi-section Solid

Pocket

Edge Fillet

Chamfer

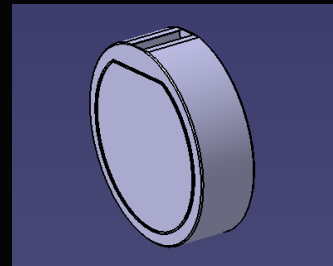
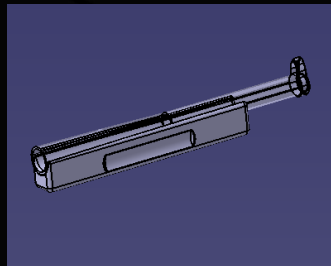
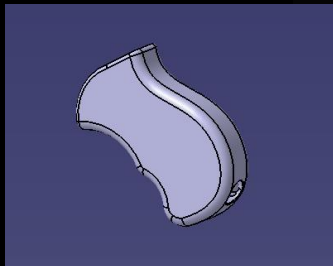
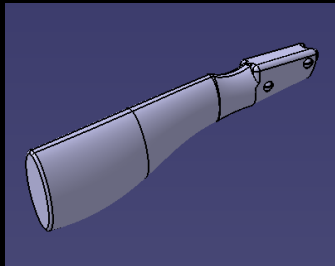

3. Modeling

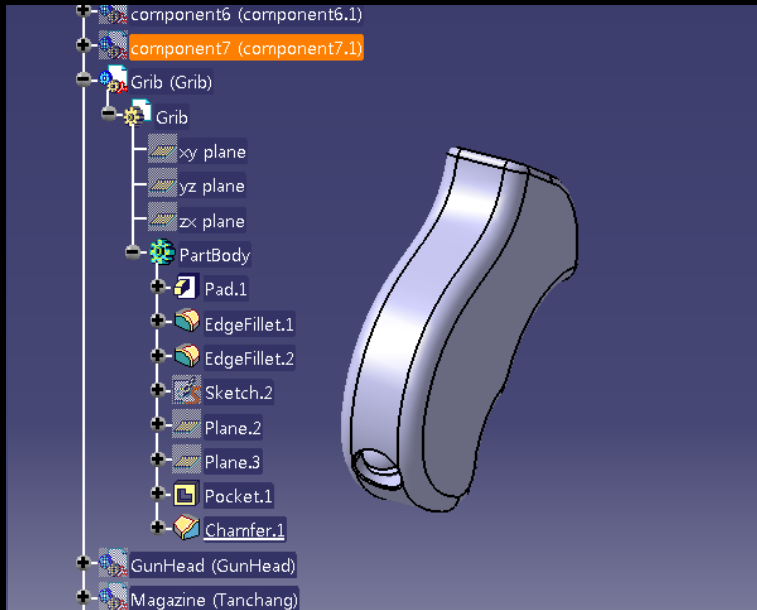

Part : 손잡이

Function
: Pad
Pocket
Edge Fillet
Chamfer

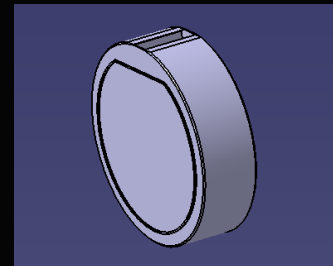
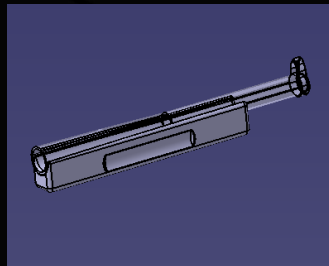
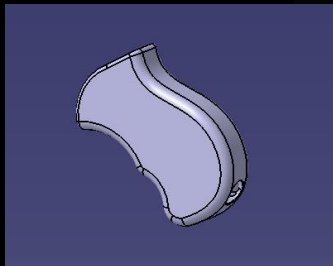
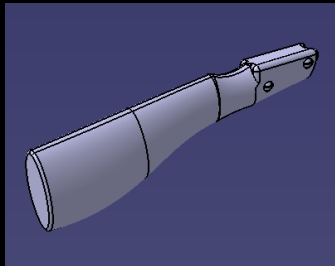

3. Modeling

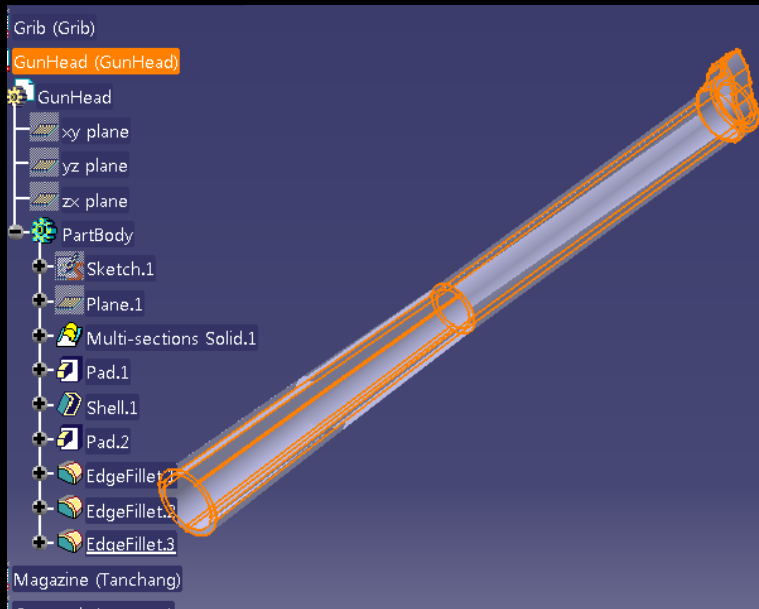

Part : 총열

Function

: Multi-Section Solid

Pad

Shell

Edge Fillet

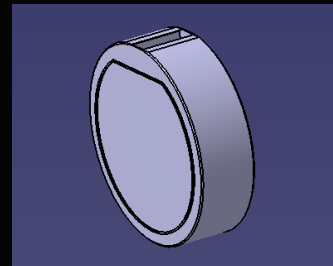
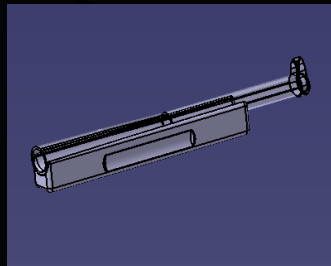
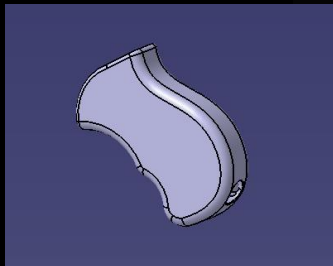
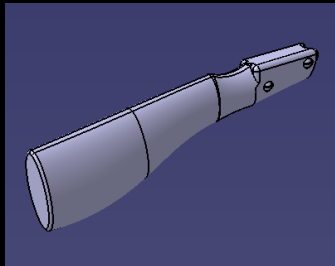

3. Modeling

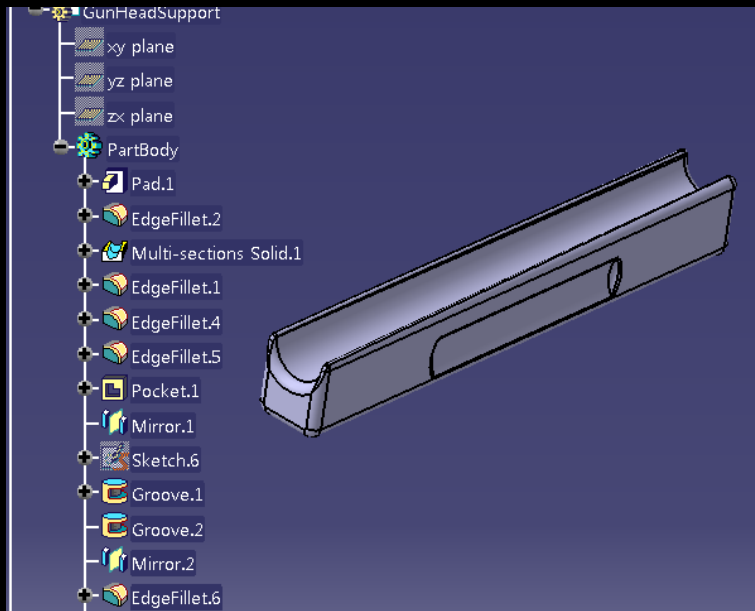

Part : 총열 받침

Function
: Pad
Pocket
Edge Fillet
Groove

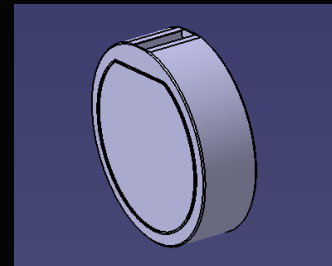
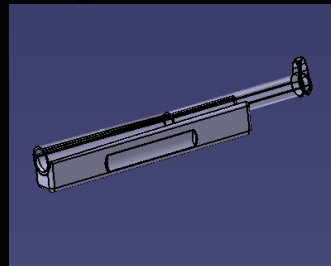
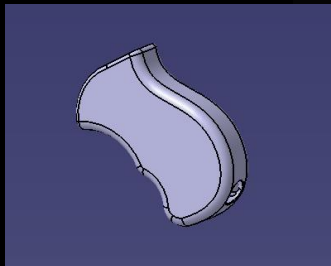
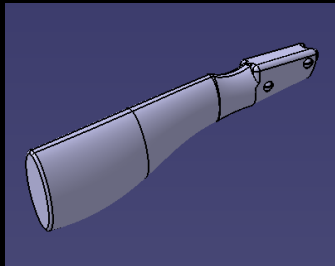

3. Modeling

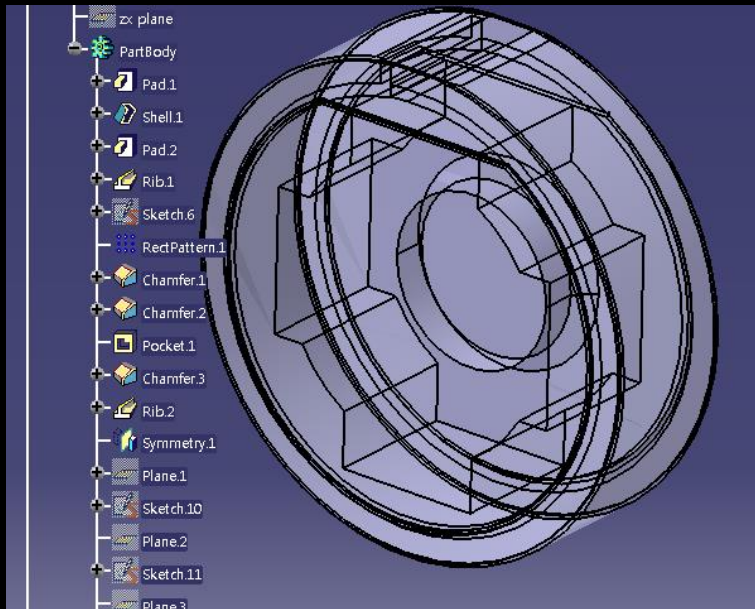

Part : 탄창

Function

: Pad

Pocket

Edge Fillet

Chamfer

Rib, Shell

Rectangular Pattern

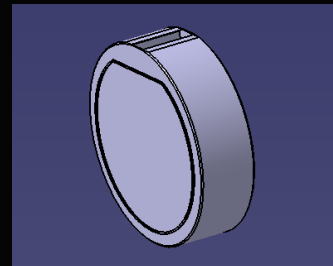
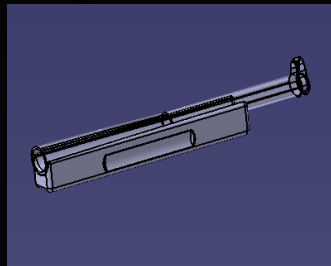
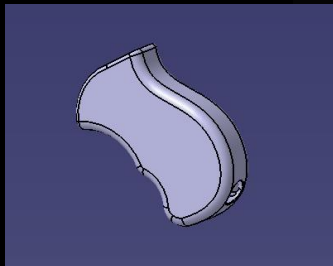
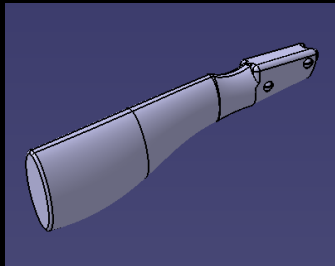

3. Modeling



Part : 스프링, 공이

Function
: Helix (GSD)

Rib

Pad

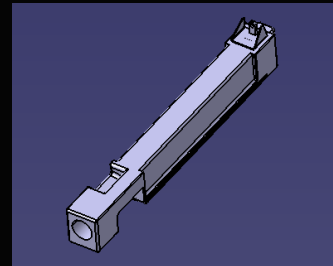
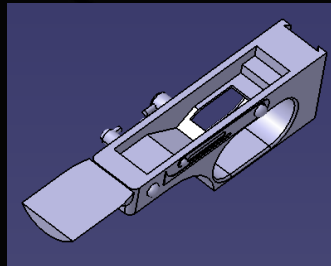
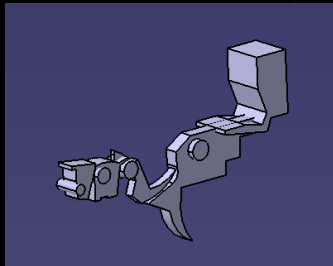
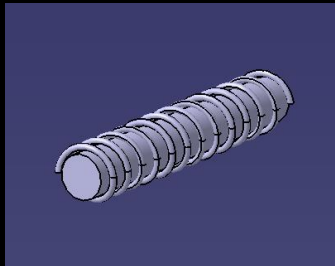

3. Modeling

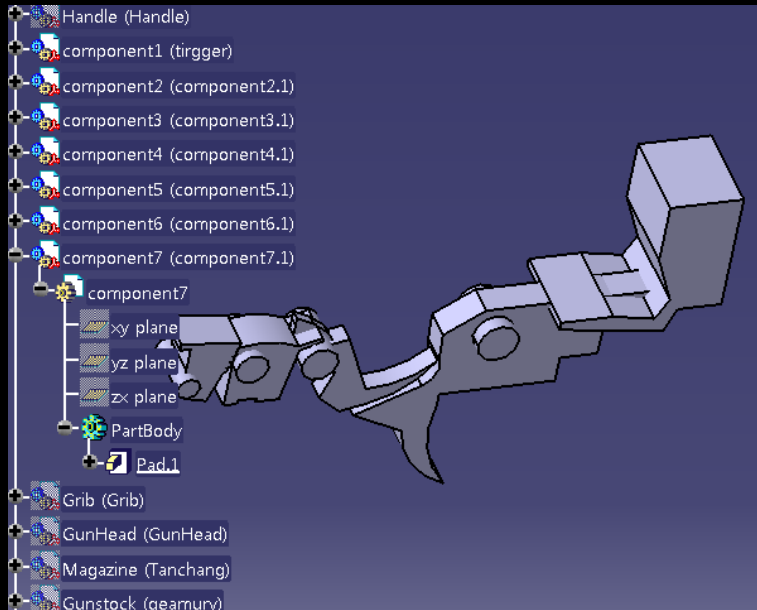

Part : 트리거 & 시어

Function
: Pad

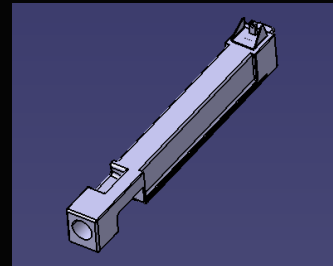
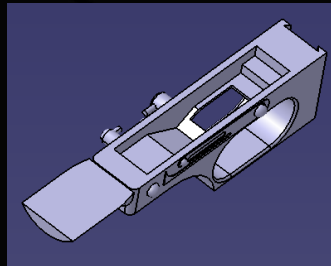
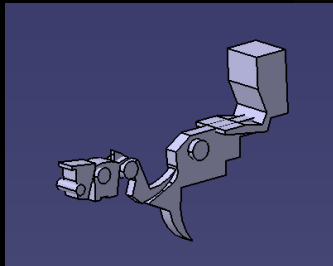
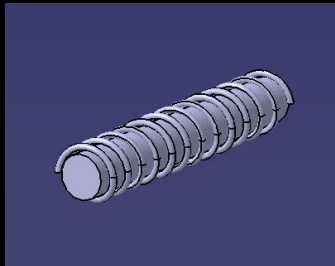

3. Modeling

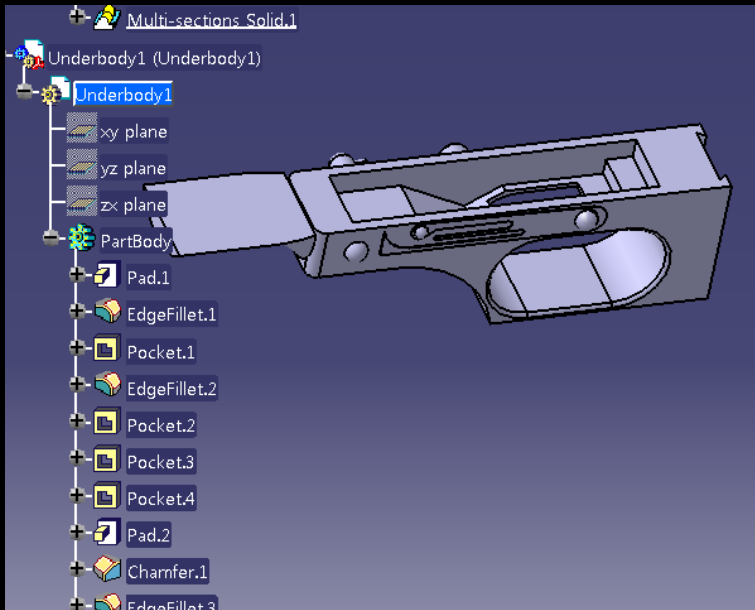

Part : 총신 하단

Function
: Pad, Pocket
Shaft
Edge Fillet
Chamfer

Multi-section Solid

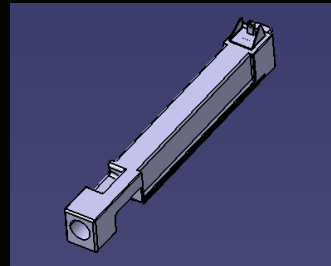
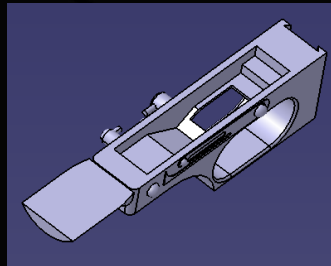
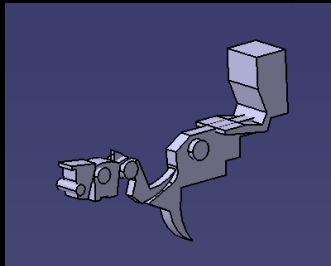
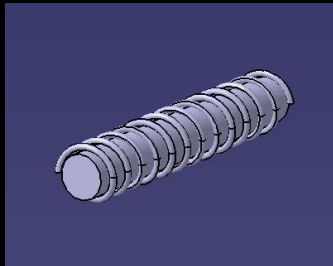

3. Modeling

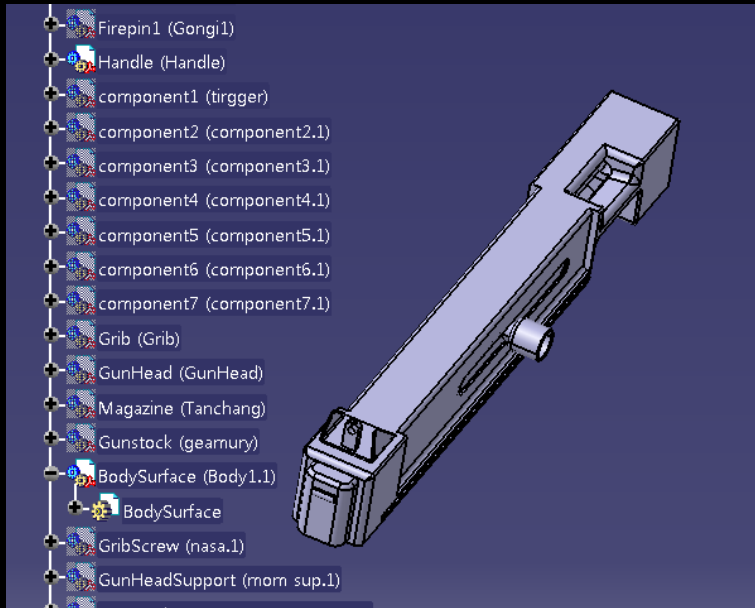

Part : 총신 상단

Function
: Pad
Pocket
Shaft
Groove
Edge Fillet

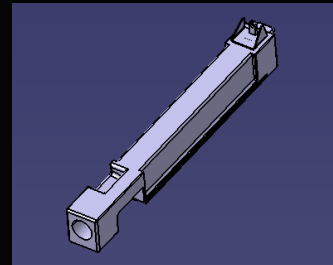
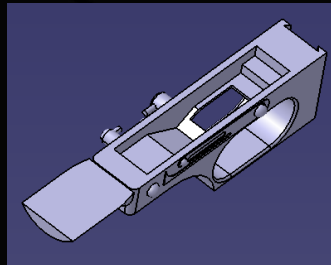
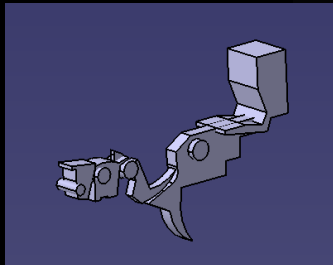
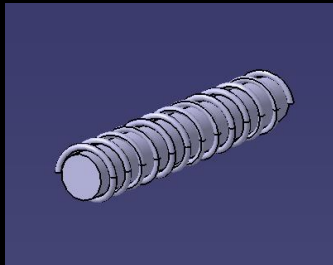

3. Modeling

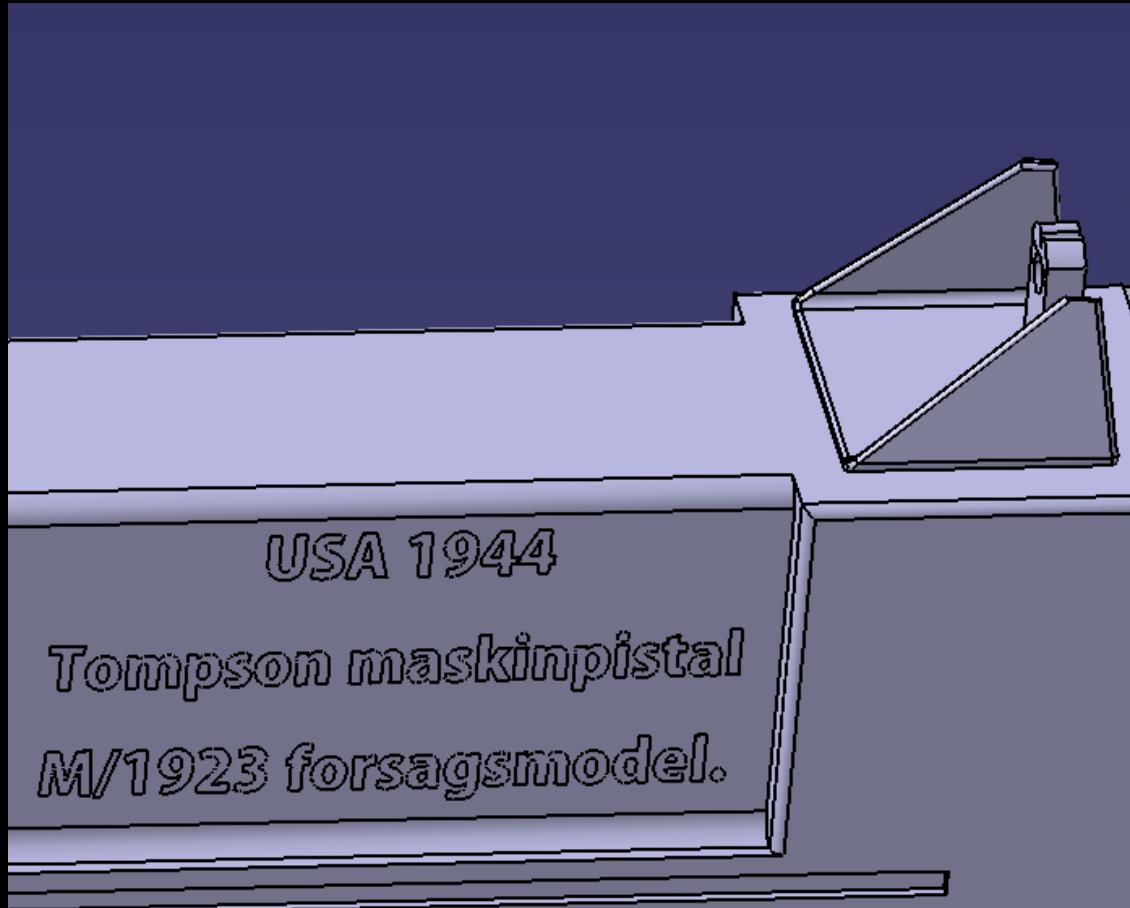

Part : 총신 이륜

Function

: Drafting

Shaft

Groove

Edge Fillet



Drawing

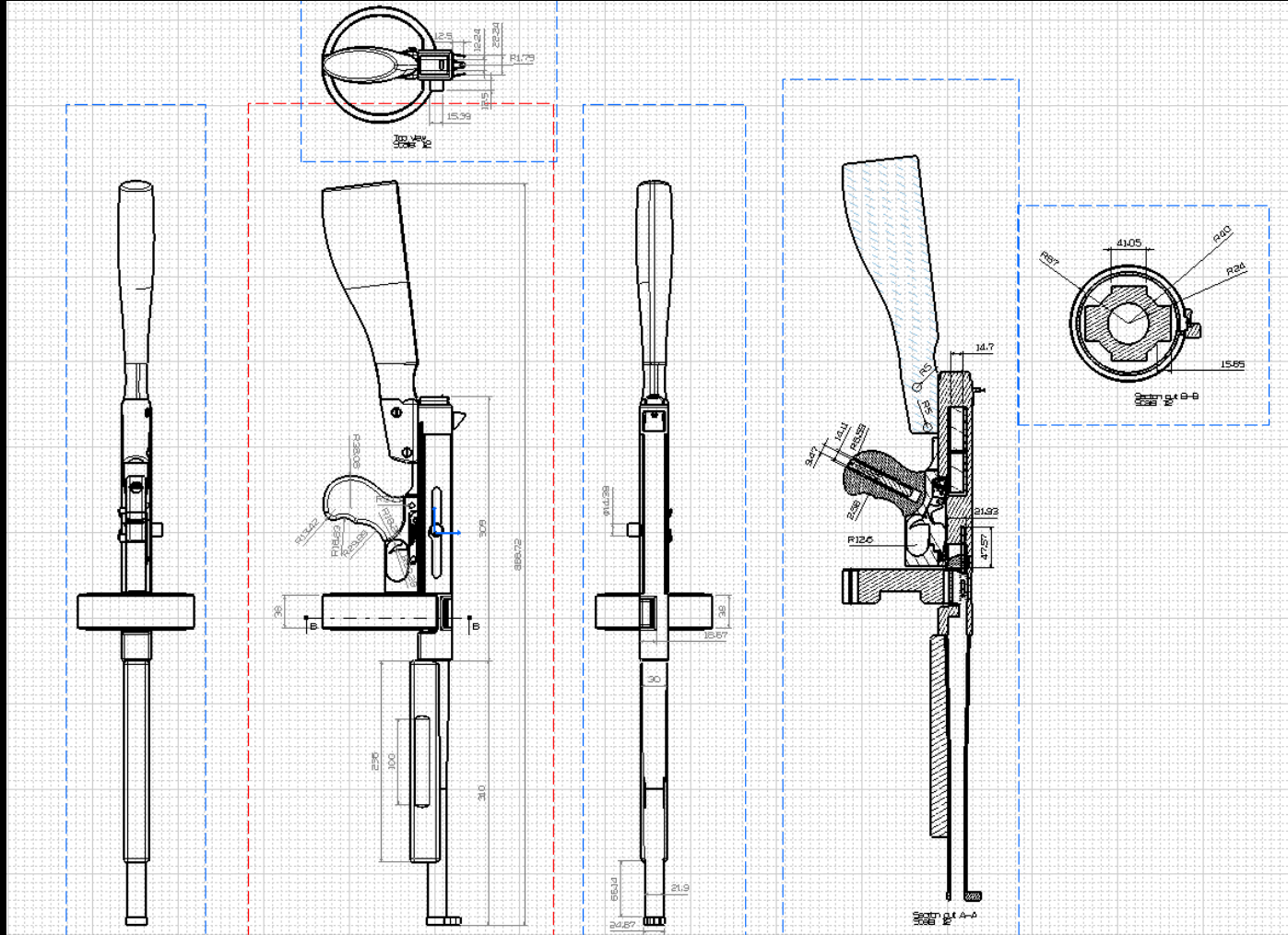

Product





4. Kinematics

4. Kinematics



4. Kinematics

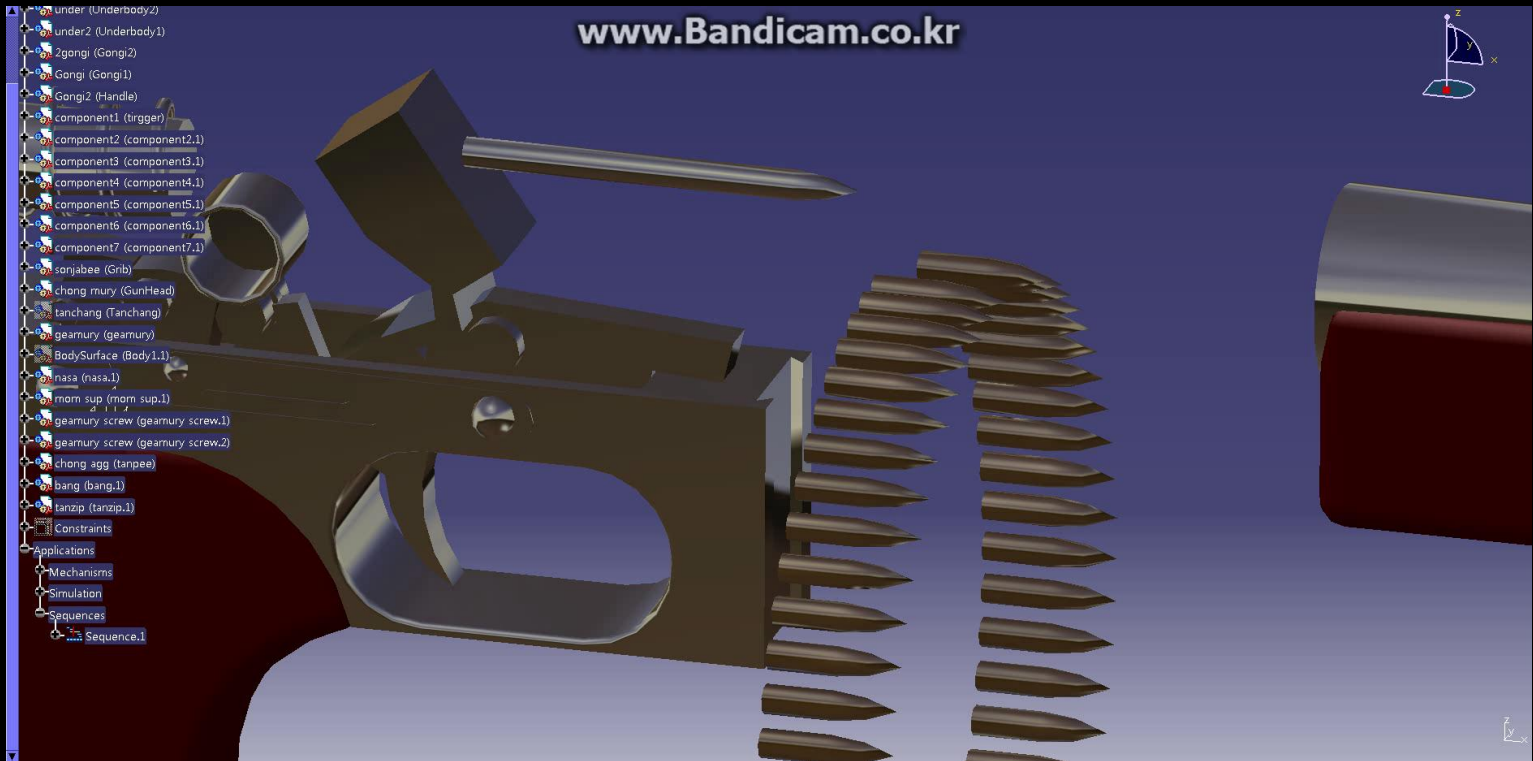

4. Kinematics



Q&A



*Thank
you~!*

