



이 자공의 탁구 이야기

2017 CAD PROJECT

TABLE TENNIS

폭주왕몽탁구



INDEX



1 팀 소개

왜 “꼭주왕 몽탁구” 일까?

2 주제 소개

어떤 주제를 준비했을까?

3 세부사항 소개

어떻게 준비를 했을까?

4 질의응답

이런 점이 궁금해!

팀 소개

왜 “폭주왕 몽탁구” 일까?



장윤희



이성준

폭주왕몽탁구

팀 소개

왜 “폭주왕 몽탁구” 일까?

폭주왕 몽탁구



미래자동차공학과



폭주자동차



정몽구연구센터



탁구



제빵왕 김탁구

주제 소개

어떤 주제를 준비했을까?

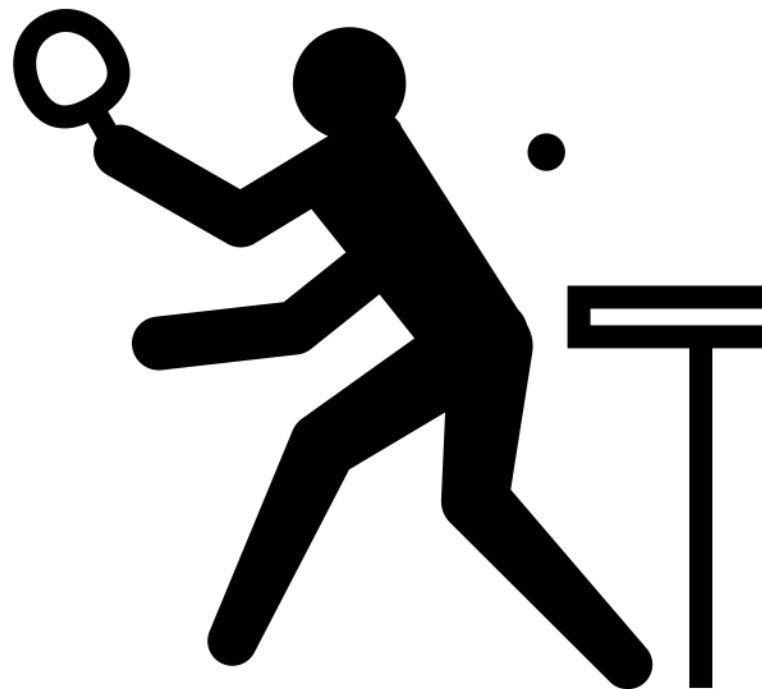
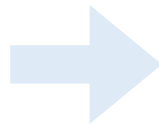
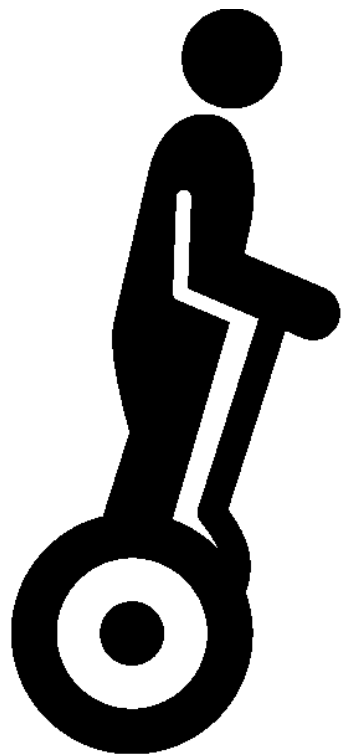

주제 소개

어떤 주제를 준비했을까?

주제 선정 배경

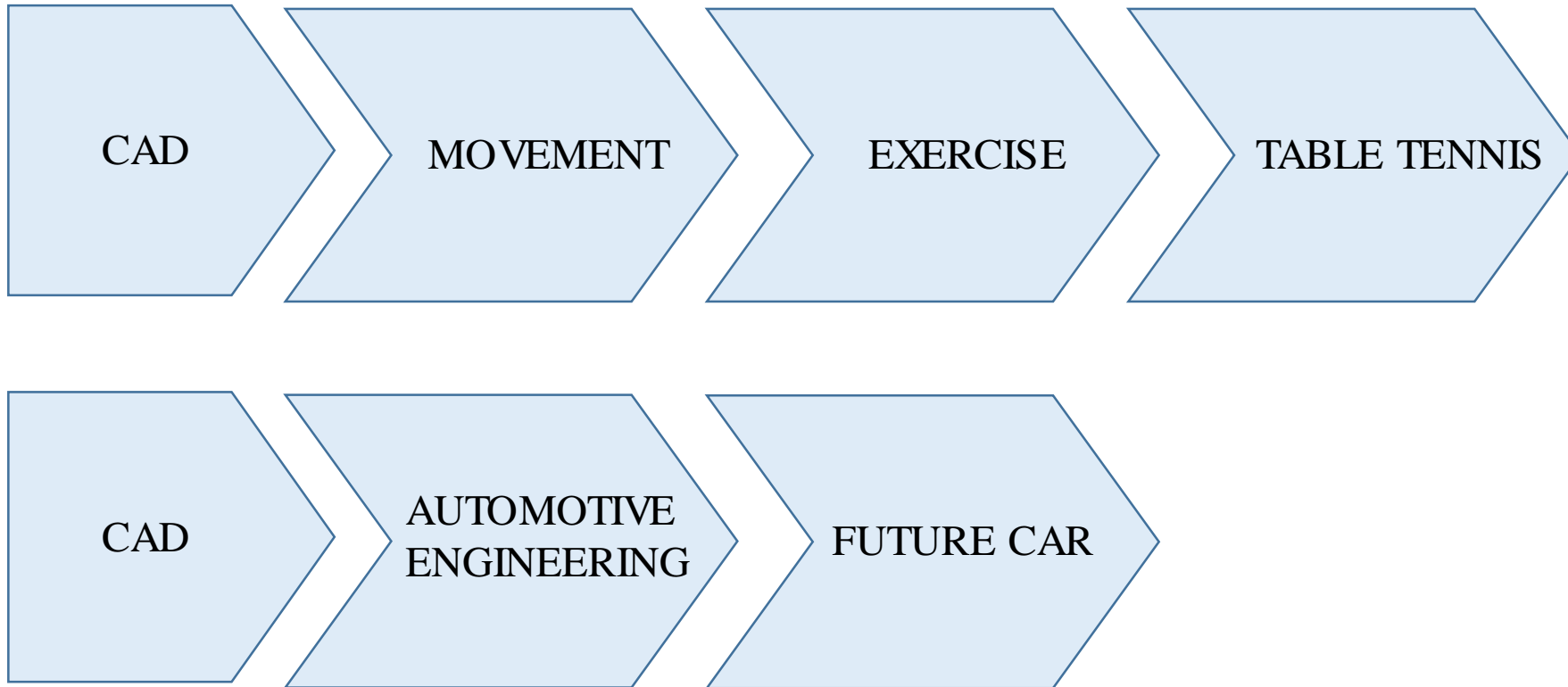

세부사항 소개

어떻게 준비했을까?

1. MOTIVE 영상



https://www.youtube.com/watch?v=afx_9klfvEI

세부사항 소개

어떻게 준비했을까?

1. MOTIVE 영상



세부사항 소개

어떻게 준비했을까?

2. 모델링

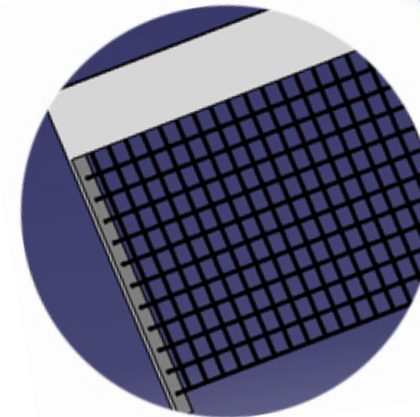
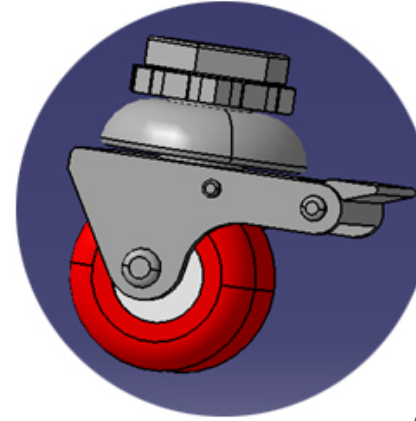
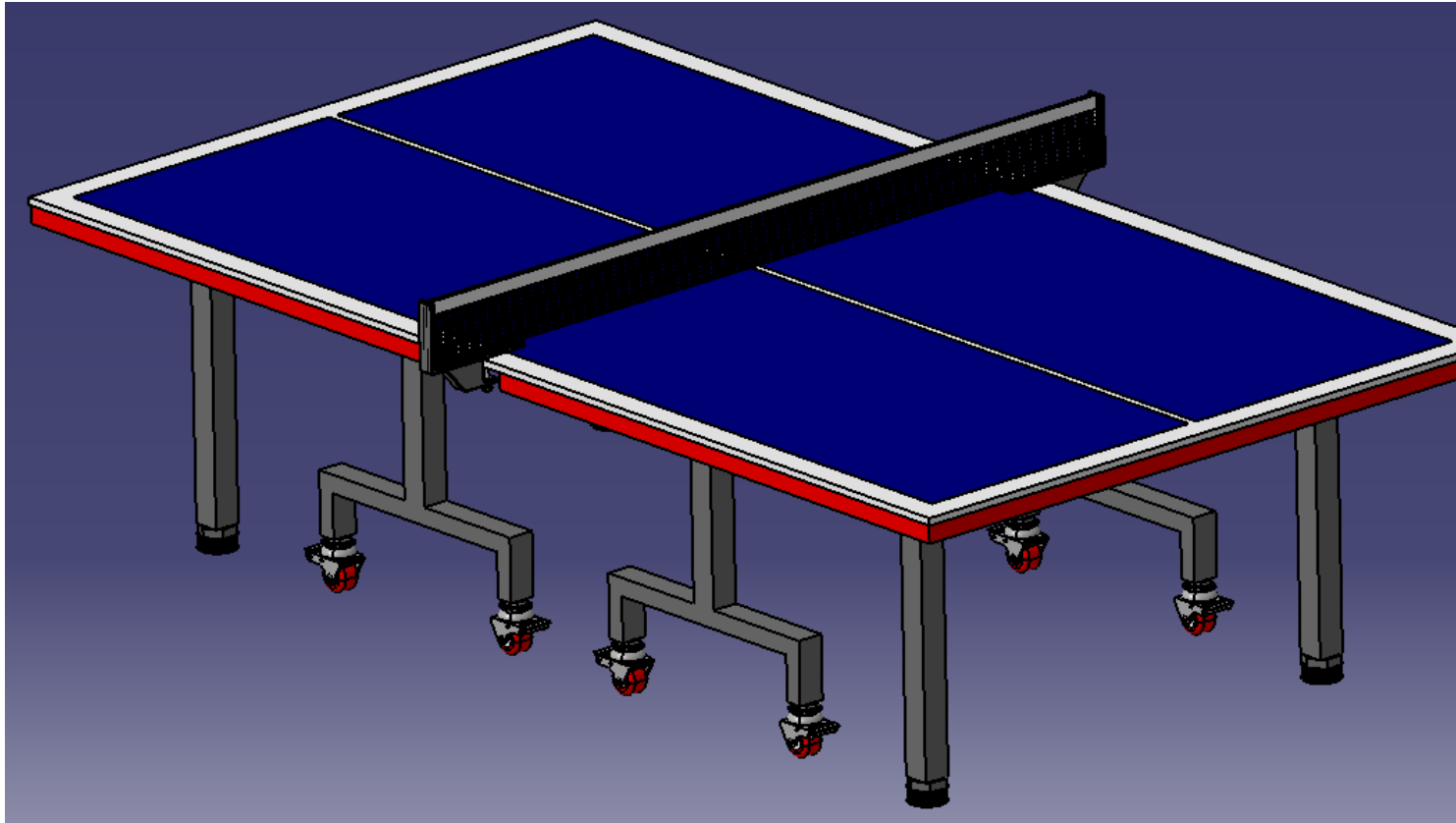

세부사항 소개

어떻게 준비했을까?

2. 모델링

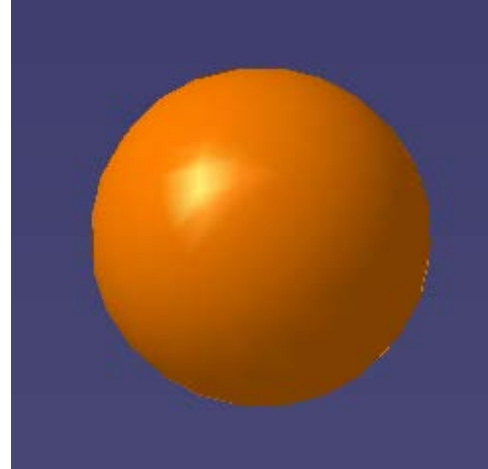

세부사항 소개

어떻게 준비했을까?

2. 모델링

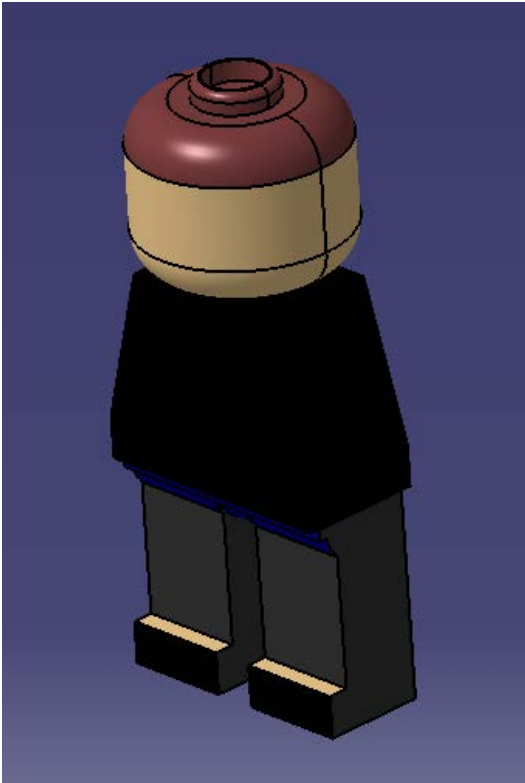

+



=



세부사항 소개

어떻게 준비했을까?

2. 모델링

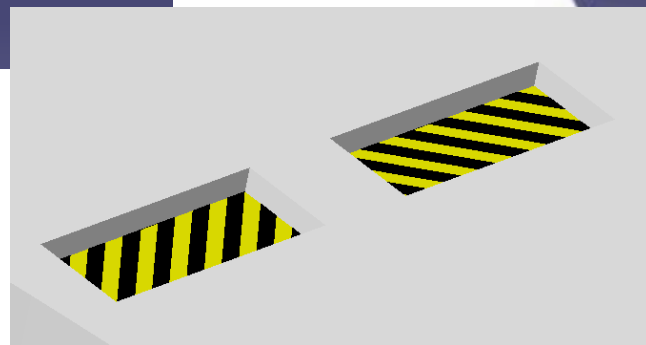
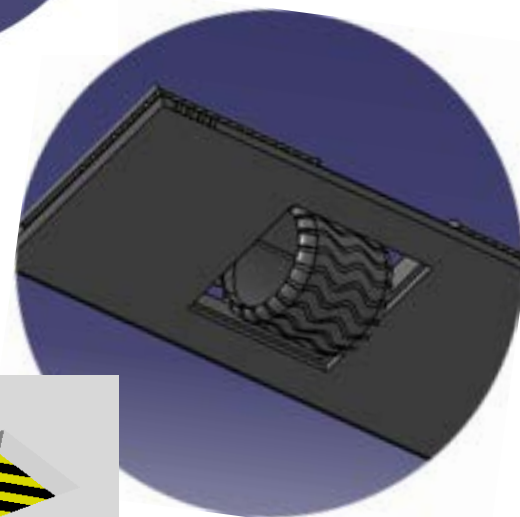
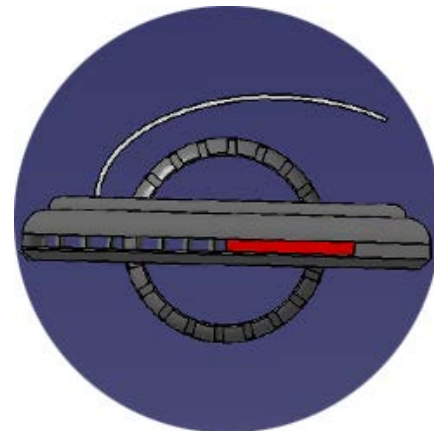
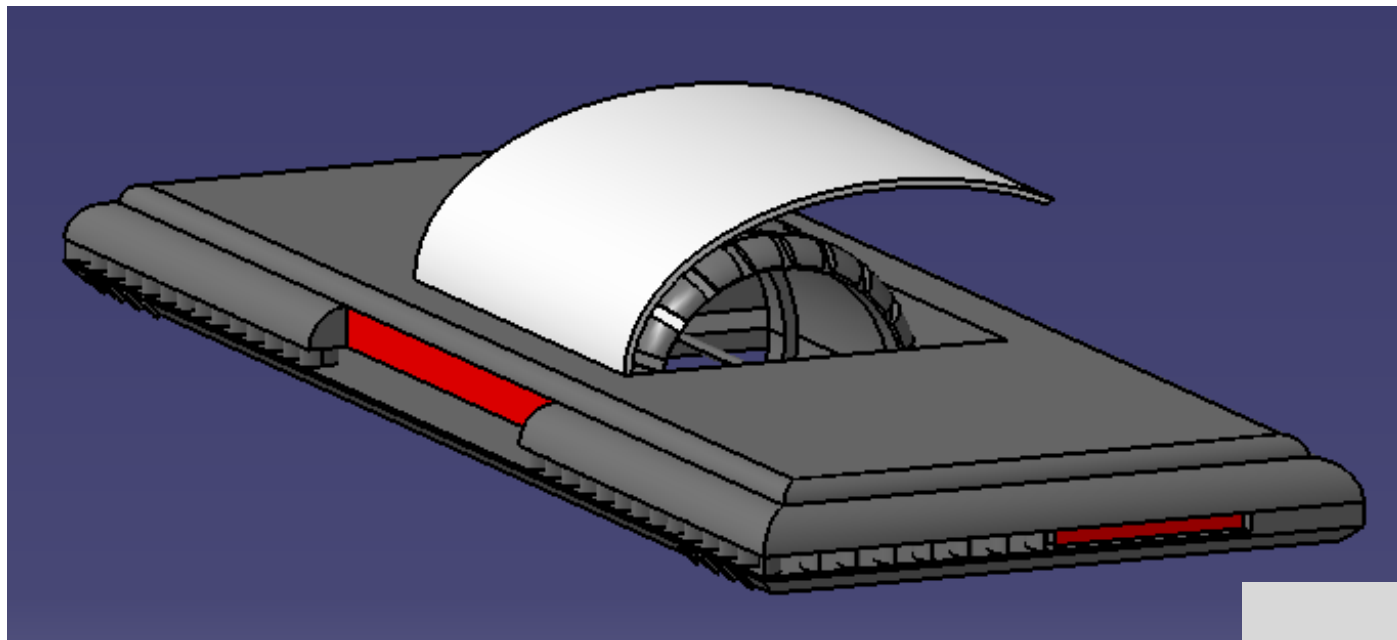

세부사항 소개

어떻게 준비했을까?

2. 모델링

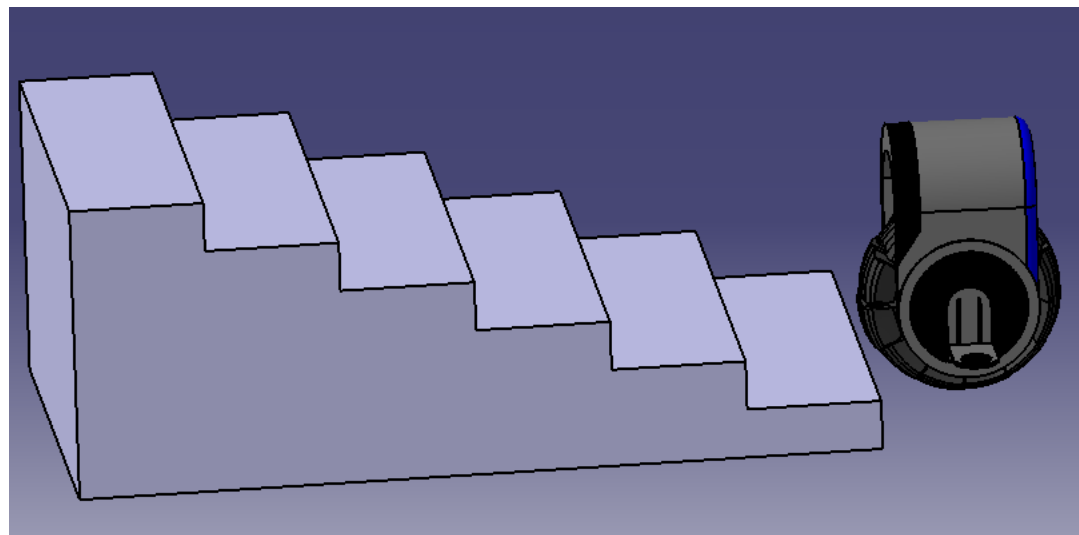
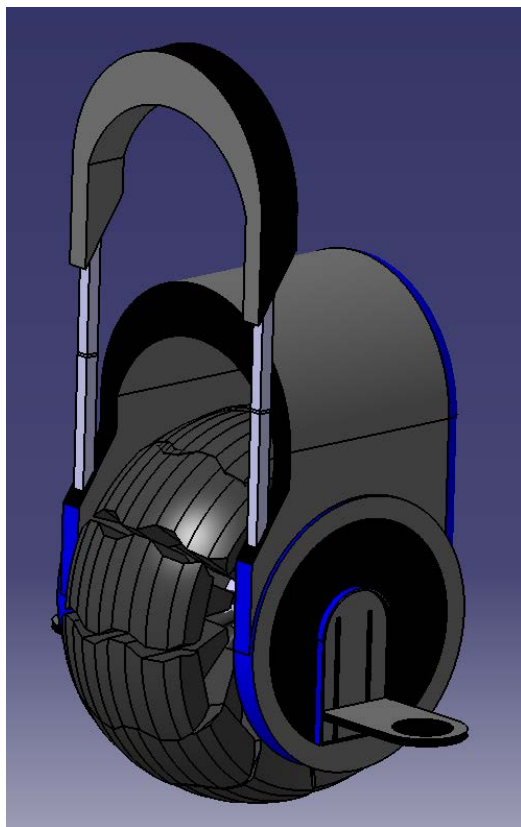
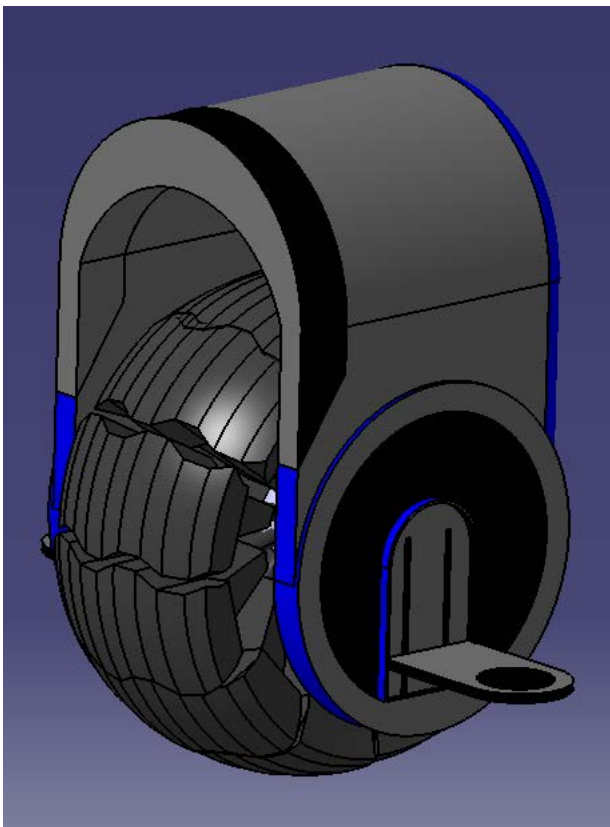

세부사항 소개

어떻게 준비했을까?

3. 전체모습

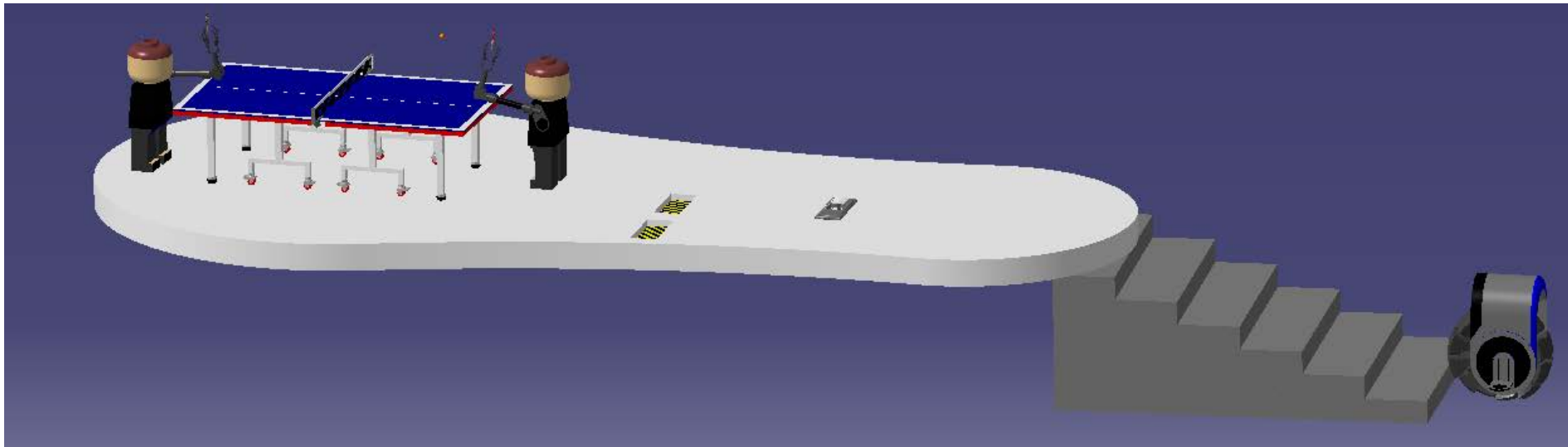
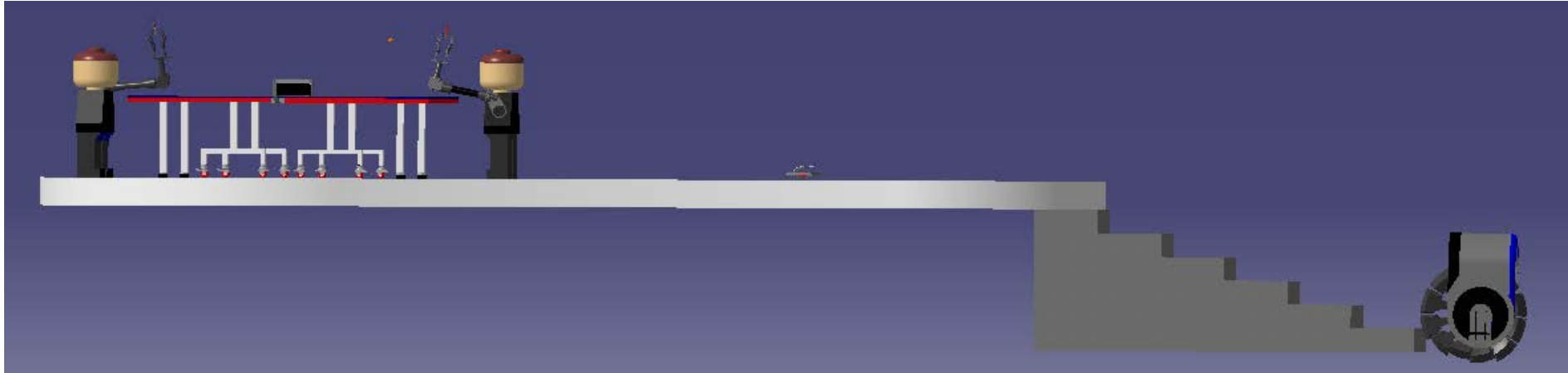

세부사항 소개

어떻게 준비했을까?

3. 전체모습

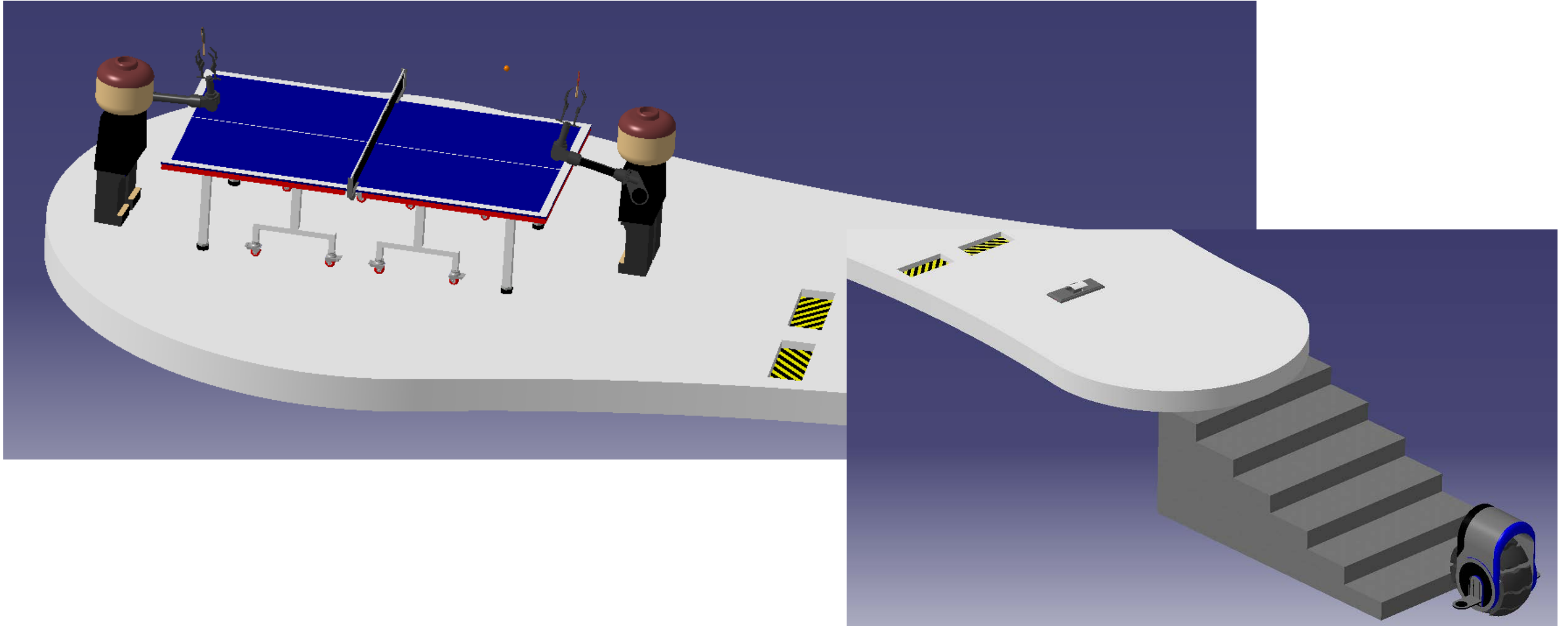

세부사항 소개

어떻게 준비했을까?

4. KINEMATICS SIMULATION

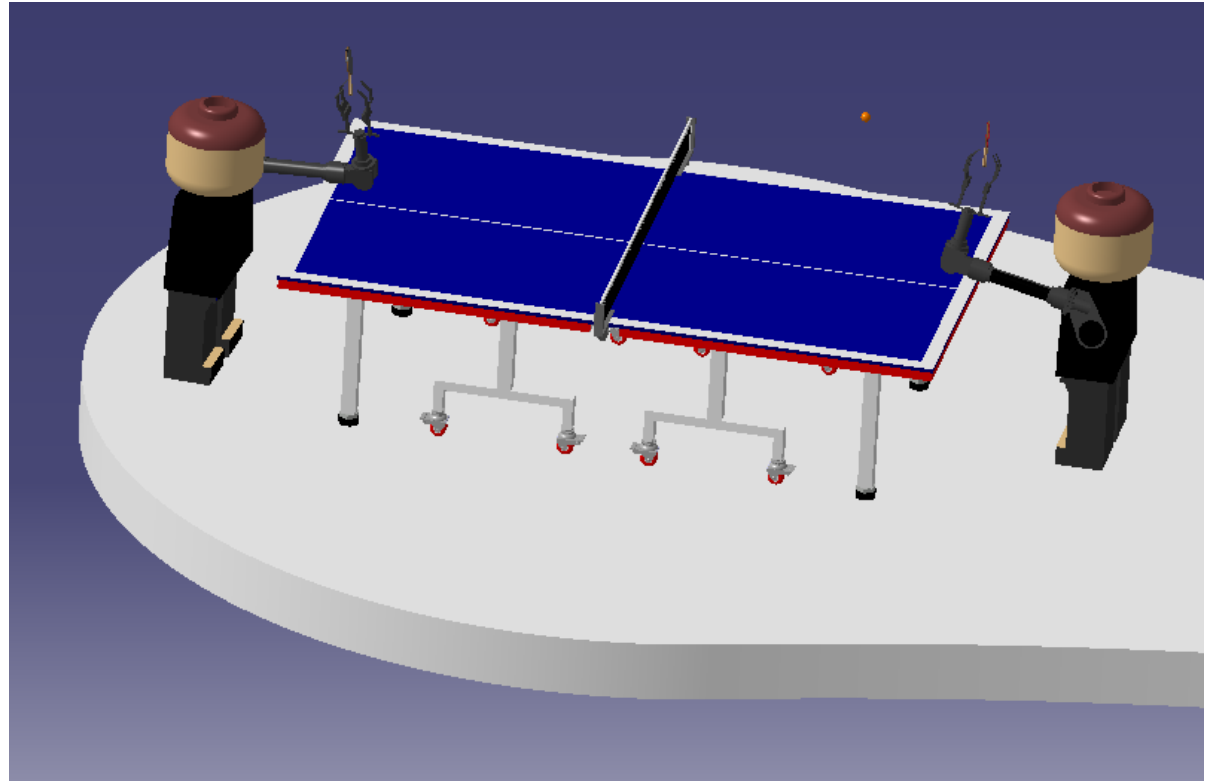
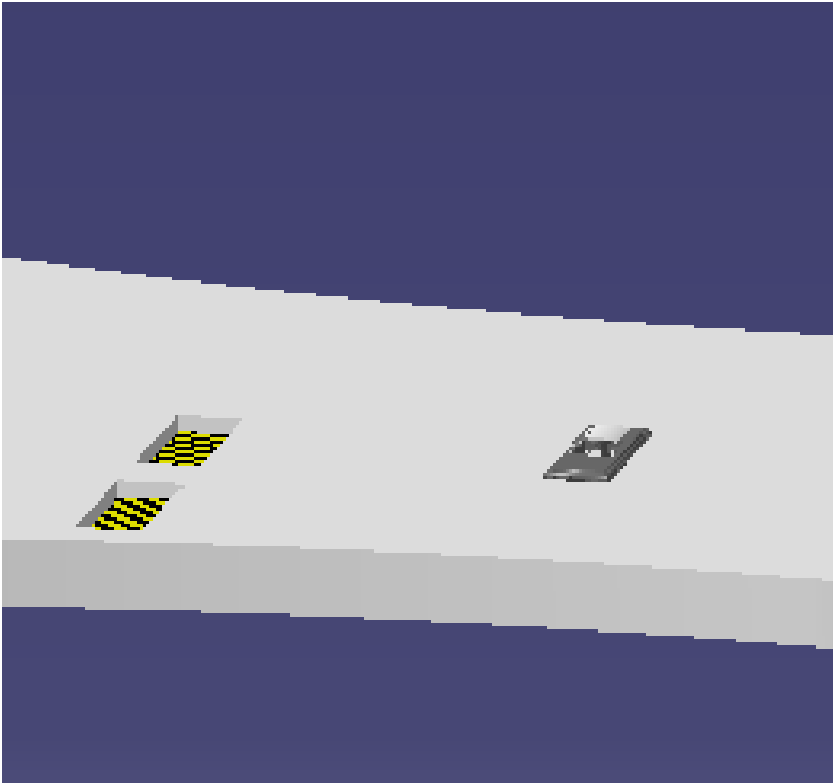

세부사항 소개

어떻게 준비했을까?

4. KINEMATICS SIMULATION

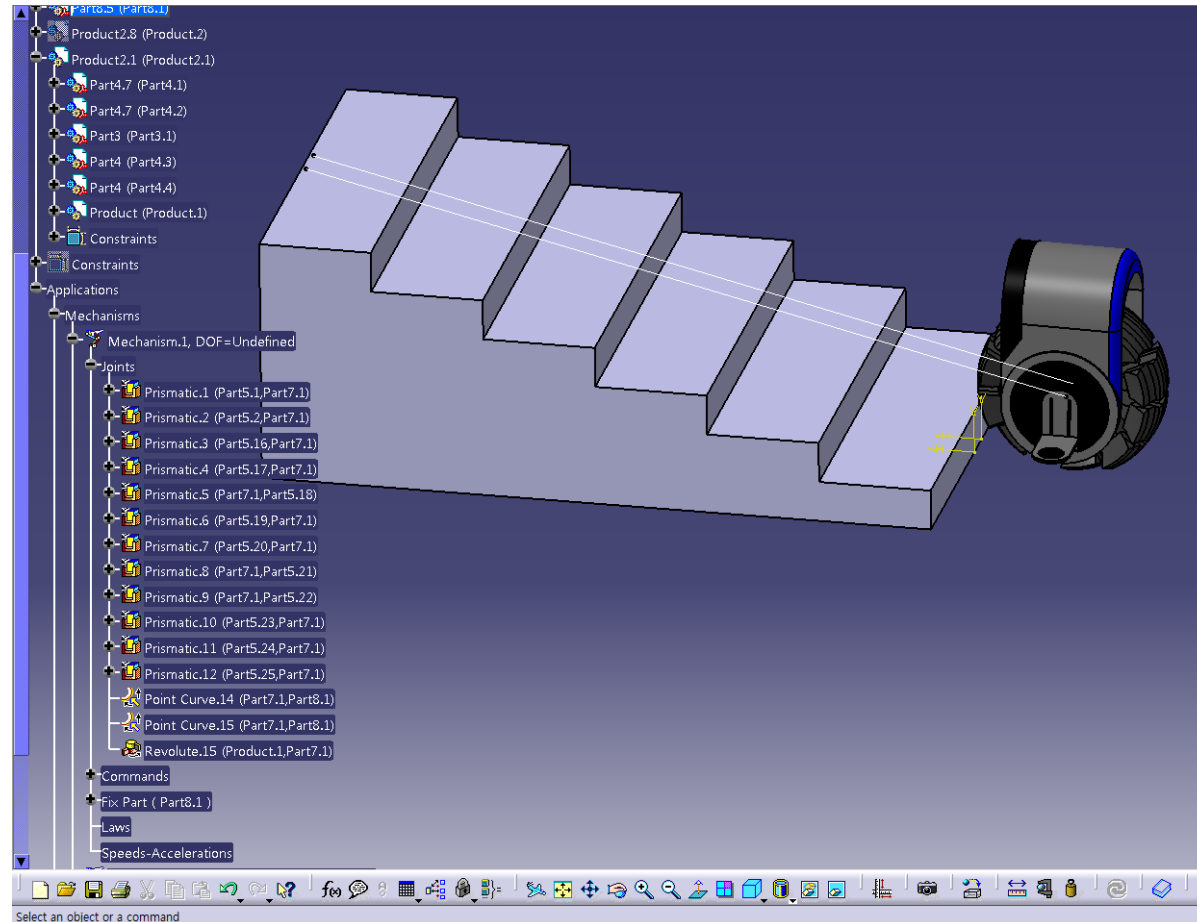
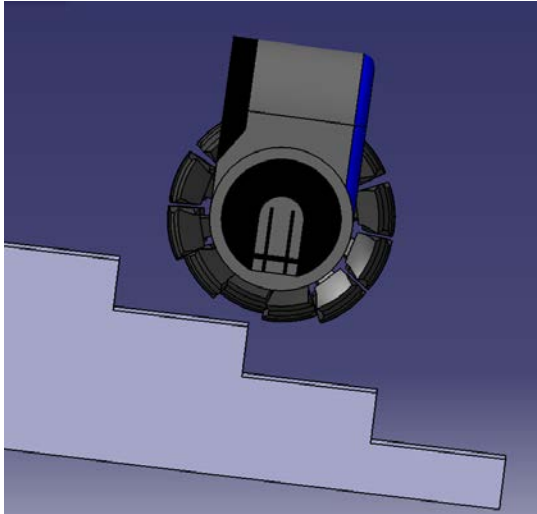

세부사항 소개

어떻게 준비했을까?

4. KINEMATICS SIMULATION

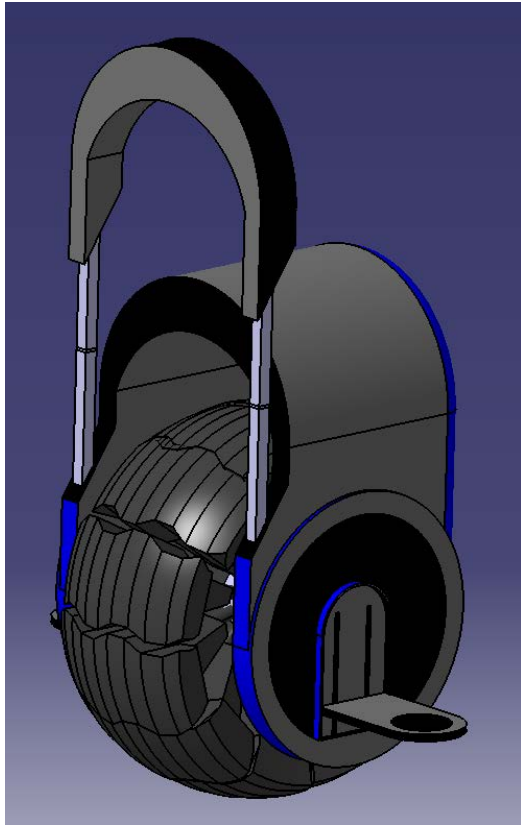

세부사항 소개

어떻게 준비했을까?

5. 출처

① 탁구대

공식적인 탁구대 규격 사이즈 (국제 탁구 연맹 규정)

② 탁구채

GRAB CAD 참고 (<https://grabcad.com/library/table-tennis-racket-2>)

③ 미래형 자동차

한국타이어 참고 (1. MOTIVE 영상 참고)

④ 로봇 팔

GRAB CAD에서 가져와 일부 변형 (<https://grabcad.com/library/robot-arm-kinematic-2>)

A man and a child are playing table tennis on a wooden table. The child is on the left, holding a paddle and hitting a ball. The man is on the right, also holding a paddle and watching the child. The scene is set against a light blue background. A white rectangular box is overlaid on the center of the image, containing the Korean text '질의응답' (Q&A).

질의응답

A photograph of a father and son playing table tennis on a wooden table. The father is kneeling on the right, and the son is standing on the left, both holding paddles and looking at a ball in the air. The image is overlaid with a semi-transparent blue filter. A white rectangular box is centered over the table, containing the text "THANK YOU!".

THANK YOU!